

Gauge Valves



**Block and Bleed Valves
Multi-Port Valves
OS&Y Valves**

Anderson Greenwood is the industry leader in instrument valve technology and the original innovator of the 3-valve manifold. Our capabilities include over 50 years of research, design and manufacture of instrumentation products. Our products are designed to be maintenance free, and are offered with numerous configurations, materials, end connections and special requirements.

Contents

Bonnet Technology

Bonnet Assemblies	1 - 2
-------------------------	-------

Block and Bleed Valve

M9 Gauge Valve

Product Overview - Features and Benefits	3
Dimensions	4
Materials, Pressure/Temperature Ratings	5
Ordering Information	6

M25 and M251 Gauge Valves

Product Overview - Features and Benefits	7
Dimensions	8
Materials, Pressure/Temperature Ratings	9
Ordering Information	10 - 11

Multi-Port Valves

M5 and M51 Gauge Valves

Product Overview - Features and Benefits	12
Dimensions	13
Materials	14
Pressure/Temperature Ratings	15
Ordering Information	16 - 19

M5A Gauge Valve

Product Overview - Features and Benefits	20
Dimensions, Materials	21
Pressure/Temperature Ratings	22
Ordering Information	23 - 24

M5F Multi-Port Gauge Valve

Product Overview - Features and Benefits	25
Dimensions, Materials	26
Pressure/Temperature Ratings, Ordering Information	27

OS&Y Root Valves

M5K, M5AK, M5YK Gauge Valves

Product Overview - Features and Benefits 28

M5K Gauge Valve

Dimensions 29
Materials, Pressure/Temperature Ratings 30 - 31
Ordering Information 32 - 33

M5AK Gauge Valve

Dimensions, Materials 34
Pressure/Temperature Ratings 35
Ordering Information 36 - 37

M5YK Gauge Valve

Dimensions, Materials 38
Pressure/Temperature Ratings 39
Ordering Information 40

Accessories

Bleed Tee

Product Overview - Features and Benefits 41
Dimensions, Materials 42
Pressure/Temperature Ratings, Ordering Information 43

V6 Bleeder Valve 44

VA Bleed Plug 44

Seat Resurfacing Tool 45

Bonnet Lock 45

Gauge Adapter 45

Gauge Syphon 45

Rod-out Device 46 - 47

Bonnet Technology

Soft-Seated Bonnet Assembly

The soft-seated bonnet assembly has a one-piece rotating stem and plug. The stem threads are rolled and lubricated to prevent galling and reduce operating torque. Available with a patented PTFE packing gland, which is adjustable in service, or with a Viton® O-ring and PTFE back-up ring. A protective dust cap is fitted to contain stem lubricant and prevent the influx of contaminants. The standard hand valves have either $\frac{3}{16}$ -inch [4.8 mm] or $\frac{1}{4}$ -inch [6.4 mm] diameter orifice size. All bonnets are assembled with a bonnet locking pin to prevent accidental removal while in service.

Metal-Seated Bonnet Assembly

The metal-seated bonnet assembly has a rotating stem with free swivel ball-type seat for long service life. The stem threads are rolled and lubricated to prevent galling and reduce operating torque. The stem seal is a patented PTFE packing gland which is adjustable in service. A protective dust cap is fitted to contain stem lubricant and prevent the influx of contaminants. The specially hardened ball seat is ideal for both gas and liquid service. All bonnets are assembled with a bonnet locking pin to prevent accidental removal while in service.

The 10,000 psig [689 barg] bonnet assembly uses a strengthened stem and bonnet. The stem seal is a patented PTFE packing gland which is adjustable in service. A protective dust cap is fitted to contain stem lubricant and prevent the influx of contaminants. This bonnet is also fitted with a larger size T-bar handle.

The high-temperature bonnet assemblies utilizes a similarly designed stem and bonnet, and incorporates adjustable GRAFOIL® O-rings and back-up pressure rings to ensure a leak-free stem seal.

Notes

1. Viton® is a registered trademark of E.I. duPont de Nemours and Company.
2. GRAFOIL® is a registered trademark of Graftech, Inc.

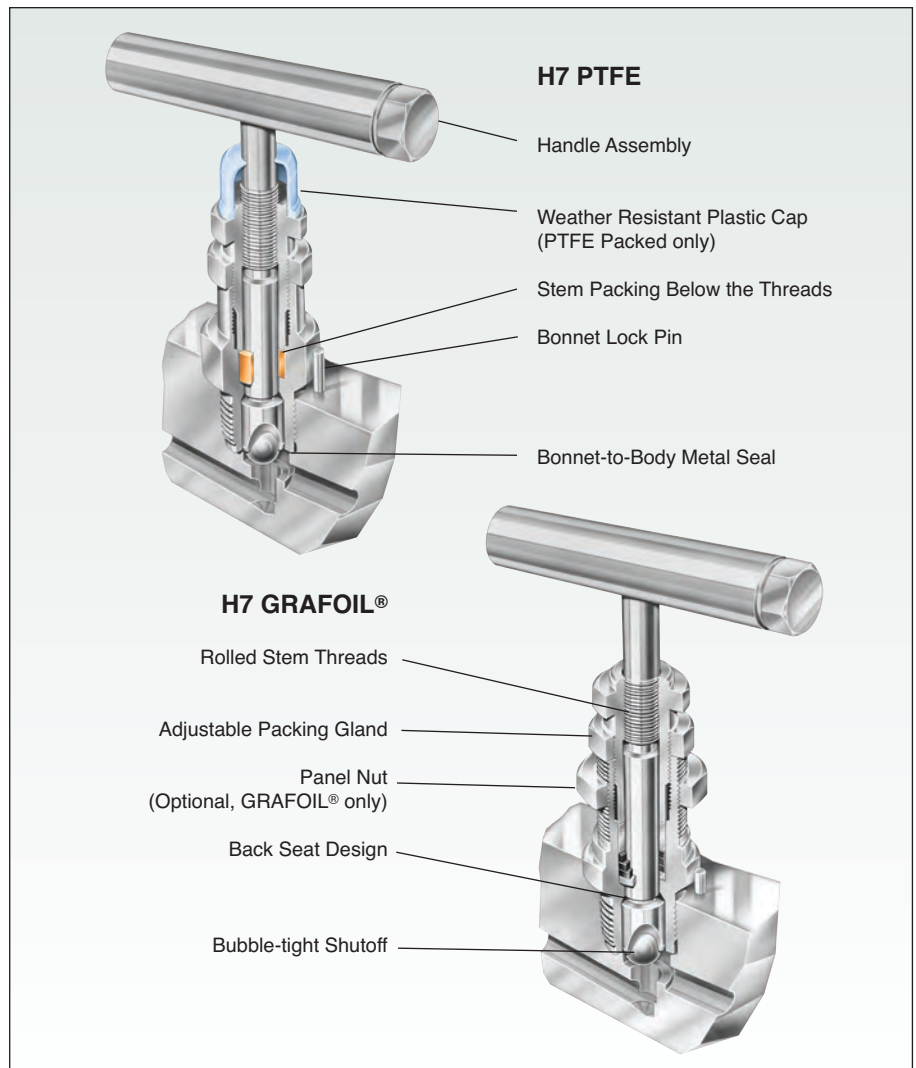
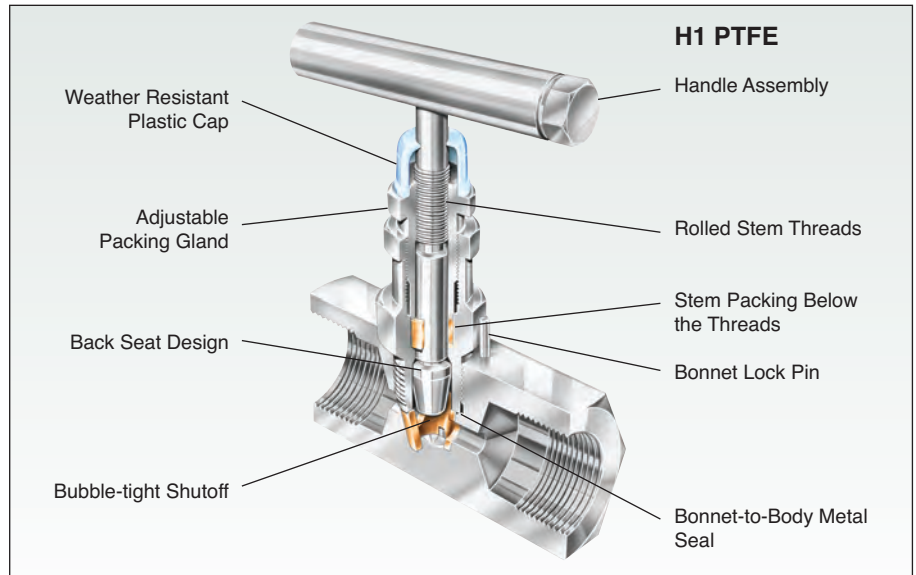

Bonnet Technology, continued

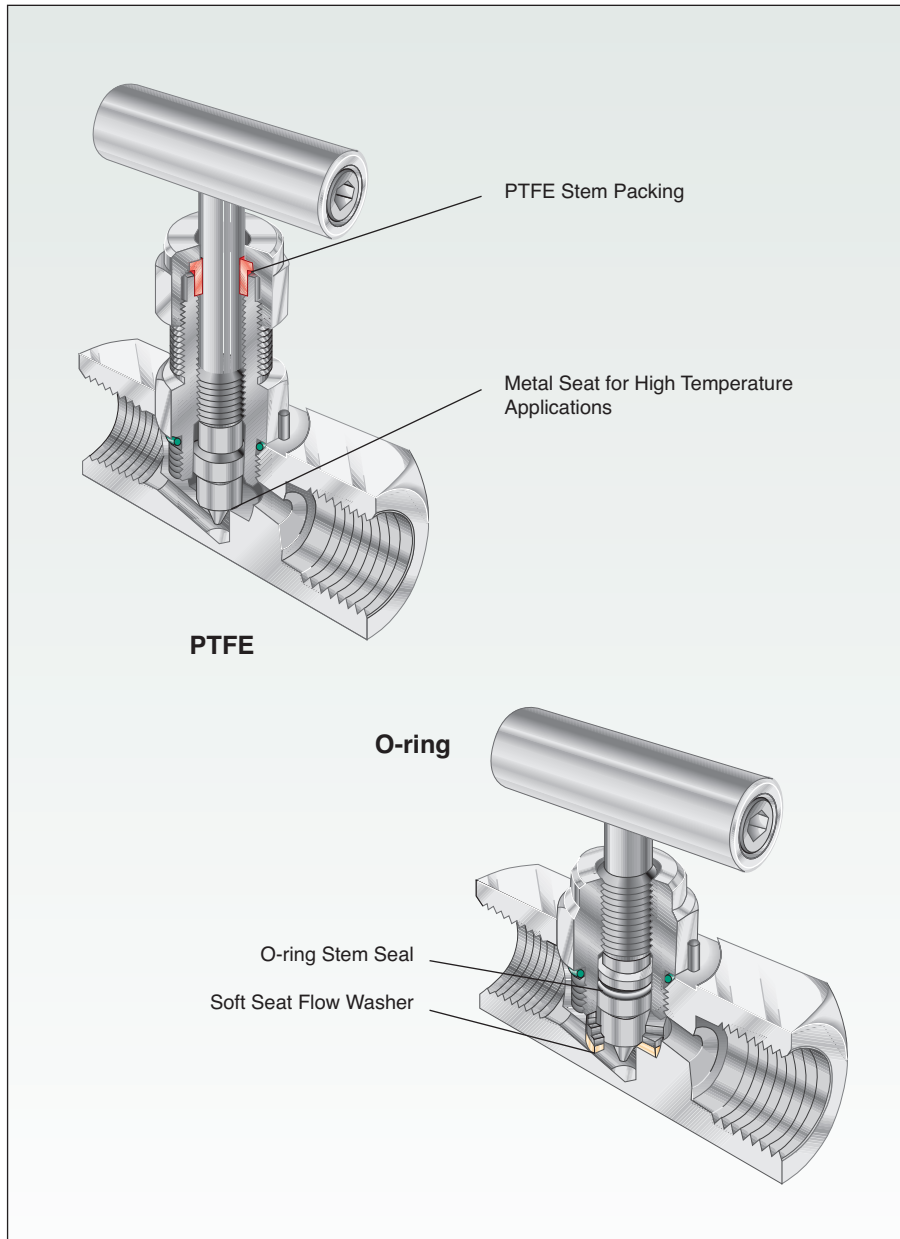

Mini-Valve Bonnet Assembly

The mini-valve bonnet assembly has a compact design with a one-piece rotating stem which is 'V' tipped with a shoulder for use as a metal or soft seated valve. The stem threads are rolled and lubricated to prevent galling and reduce operating torque.

The mini-valve bonnet comes in three designs. An adjustable PTFE stem packed bonnet is suitable for panel mounting via external bonnet threads. The O-ring bonnet assemblies use a Viton® O-ring seal below the stem thread.

A GRAFOIL® packed bonnet suitable for temperatures of up to 500°F [260°C] is available for SS valves only.

Arctic Lube

The low temperature rating for standard Anderson Greenwood carbon steel and 316 stainless steel instrumentation products is -20°F [-28°C] (standard products - standard lubrication). Our -AL (Arctic Lube) option extends the lower temperature limit to -70°F [-57°C] on all stainless steel models.

Block and Bleed Gauge Valve – M9

Product Overview

The M9 (block and bleed) gauge valve is specifically designed to facilitate safe, compact, and economical gauge installation and operation.

Block valve seating is interchangeable between 'hard' or 'soft' without changing the bonnet assembly. This feature enhances the value of the M9 by extending the useful life of the valve.

The M9's Bleed Plug is integral and employs metal-to-metal seating. It enables pressure to be safely vented without breaking threaded connections.



Applications

Static pressure gauge and instrument installation for isolation and venting.

Features and Benefits

- **Packing below threads (O-ring bonnet)** prevents lubricant washout, thread corrosion, and keeps solids from entering thread area, which can cause galling. It also prevents process contamination.
- **Adjustable packing** – Teflon® and GRAFOIL® packed bonnets adjust easily, decreasing packing replacement downtime and increasing valve life.
- **Safety back seating** prevents stem blowout or accidental removal while in operation and provides a metal-to-metal secondary stem seal while in the full open position.
- **Chrome plating of 316 SS stem** prevents galling or freezing of stem threads when similar metals mate. CS valves use a 303 SS stem.
- **Rolled threads** provide additional thread strength. The stem, bonnet, and male NPT threads are rolled, not cut.
- **Mirror stem finish** burnished to a 16 RMS finish in the packing area enabling smooth stem operation and extending packing life.
- **One-piece handle design** prevents loss of the valve handle due to vibration or during maintenance.
- **Soft or metal seat for bubble-tight shutoff** is field replaceable for easy maintenance.
- **Extended valve life** – if soft seat becomes damaged it can be removed, leaving a metal seated valve.

Note

1. Teflon® is a registered trademark of E.I. duPont de Nemours and Company.

Block and Bleed Gauge Valve – M9 Specifications⁴

M9RIS – 44 Dimensions with O-ring Bonnet¹, inches [mm]

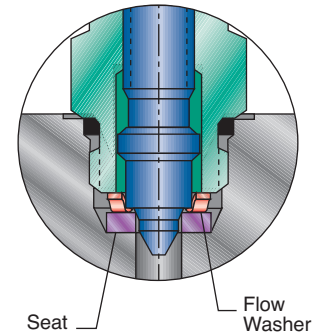
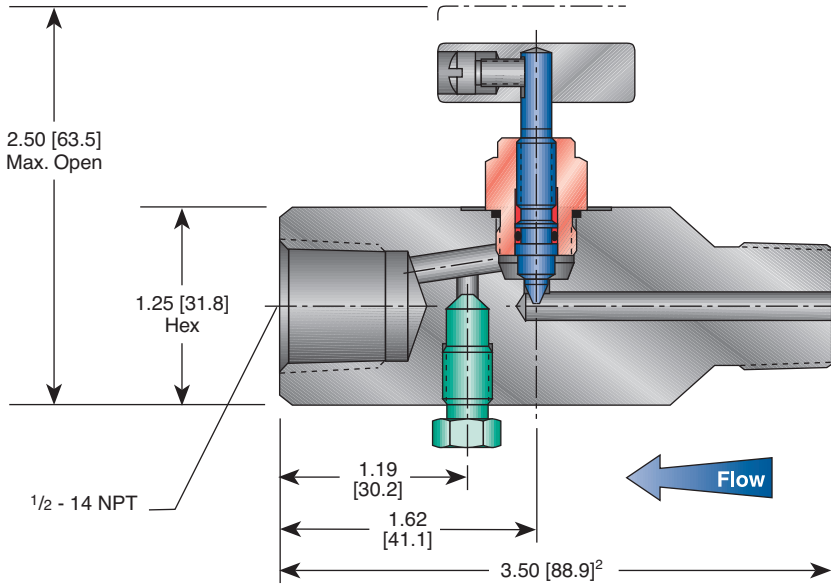

Optional Soft Seat

M9VIS – 4M Dimensions with Teflon[®] Bonnet¹, inches [mm]

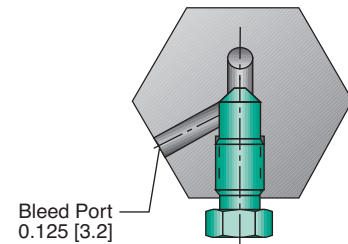
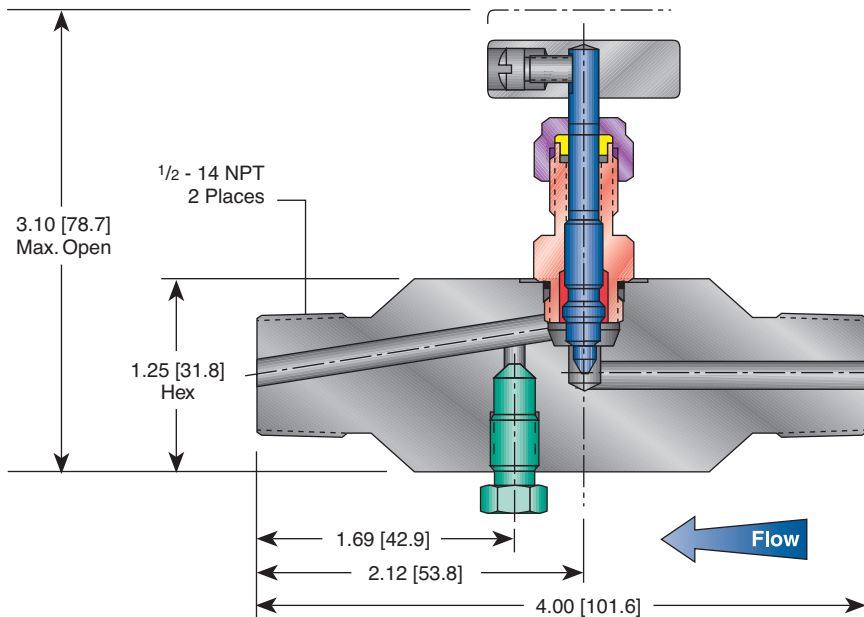

Section Through Bleed Plug

Notes

1. Bonnets interchangeable between all body configurations.
2. 4.00-inch [101.6 mm] for -44C, -46C.
3. M9()-4 body length 2.88-inch [73.2 mm].
4. For Hastelloy[®] and SG3 call factory for dimensions and weights.
5. Hastelloy[®] is a registered trademark of Haynes International.

Block and Bleed Gauge Valve – M9 Specifications

Standard Materials

Metal Seat

Valve ¹	Body	Bonnet	Stem	Packing	Bleed Plug	Seat
CS ²	A108 CS	A108 CS	A581-303 SS	Teflon® or BUNA-N O-ring	A108 CS	Integral
SS	A479-316 SS	A479-316 SS	A276-316 SS	Teflon®, BUNA-N O-ring or GRAFOIL®	A276-316 SS	Integral
SG ³	A479-316 SS	A479-316 SS	Monel® 400	Teflon®	A279-316 SS	Integral
Monel®	Monel® R405	Monel® R405	Monel® R405	Teflon®	Monel® R405	Integral
SG3 ³	Hastelloy® C-276	Hastelloy® C-276	Hastelloy® C-276	Teflon®	Hastelloy® C-276	Integral

Soft Seat

Valve ¹	Body	Bonnet	Stem	Packing	Flow Washer	Bleed Plug	Seat ⁴
CS ²	A108 CS	A108 CS	A581-303 SS	Teflon® or BUNA-N O-ring	316 SS	A108 CS	Delrin®
SS	A479-316 SS	A479-316 SS	A276-316 SS	Teflon® or Viton® O-ring	316 SS	A276-316 SS	PCTFE ⁵
SG ²	A479-316 SS	A479-316 SS	Monel® 400	Teflon®	316 SS	A276-316 SS	PCTFE ⁵
SG3 ³	Hastelloy® C-276	Hastelloy® C-276	Hastelloy® C-276	Teflon®	Hastelloy® C-276	Hastelloy® C-276	PCTFE ⁵

Notes

- Approximate valve weight 1.2 lb [.54 kg].
Orifice size 0.136-inch [3.5 mm] diameter.
Valve C_v Hard Seat 0.25 maximum. Valve C_v Soft Seat 0.24 maximum.
- CS is zinc-cobalt plated to prevent corrosion (except male plain end is black oxide coated).
- SG (Sour Gas) meets the requirements of NACE MR0175/ISO 15156-3 Corrigendum 2 (for Chloride conditions ≤ 50 mg/l [ppm]) and NACE MR0103-2005.
- PEEK available.
- PCTFE (Polychlorotrifluoroethylene) is the exact equivalent of Kel-F®.
- Kel-F®, Viton® and Delrin® are registered trademarks of E.I. duPont de Nemours and Company.
- Monel® is a registered trademark of the Special Metals Corporation.
- SG3 (Sour Gas) meets the requirements of NACE MR0175/ISO 15156-3 Corrigendum 2 (for Chloride conditions > 50 mg/l [ppm]).

Pressure and Temperature Ratings

Ratings with Teflon® or GRAFOIL® Bonnet

Hard Seat	6000 psig @ 200°F
	[414 barg @ 93°C]
Delrin® and PCTFE ⁵	4000 psig @ 500°F
	[276 barg @ 260°C]
PEEK Seat	3000 psig @ 200°F
	[207 barg @ 93°C]
PEEK Seat	6000 psig @ 200°F
	[414 barg @ 93°C]
PEEK Seat	3000 psig @ 300°F
	[207 barg @ 149°C]

Ratings with O-ring Bonnet

Hard Seat	6000 psig @ 200°F
	[414 barg @ 93°C]
Delrin® and PCTFE ⁵	3000 psig @ 200°F
	[207 barg @ 93°C]
PEEK Seat	6000 psig @ 200°F
	[414 barg @ 93°C]

Pressure vs. Temperature

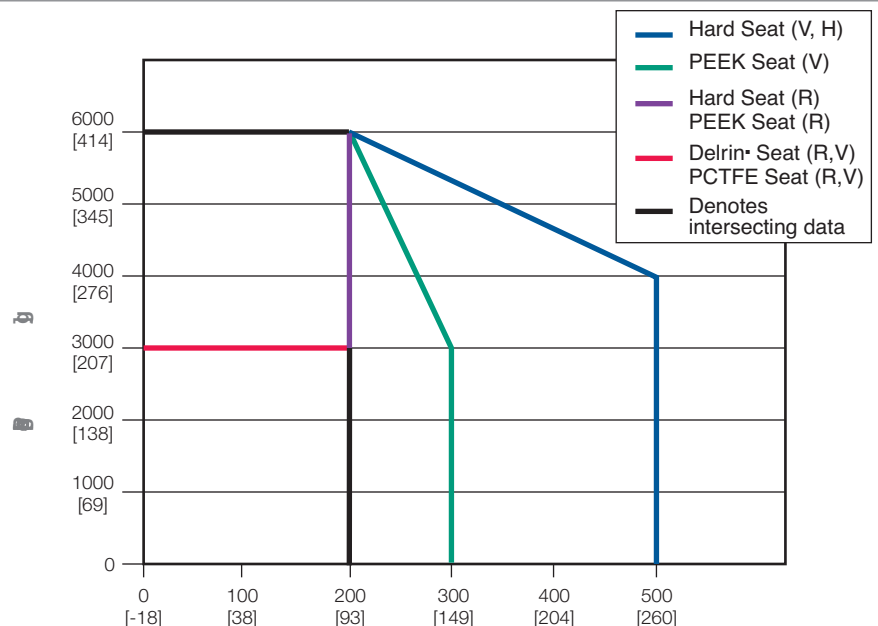

(V) = with Teflon® Bonnet Assembly
(R) = with O-ring Bonnet Assembly
(H) = with GRAFOIL® Bonnet Assembly

Block and Bleed Gauge Valve – M9 Specifications

Ordering Information

M9 V I S – 44C – SG

Packing

- V – Teflon® Bonnet (standard for 316 SS)
- R – O-ring Bonnet
- H – GRAFOIL® (500°F [260°C] max)

Seat

- I – Integral
- D – Delrin® (standard)
- E – PEEK
- K – PCTFE¹

Body Materials

- C – CS
- S – SS
- M – Monel®
- J – Hastelloy®

Connections (Inlet/Outlet)

- 44 – 1/2-inch MNPT x 1/2-inch FNPT
- 46 – 3/4-inch MNPT x 1/2-inch FNPT
- 4M – 1/2-inch MNPT x 1/2-inch MNPT
- 4 – 1/2-inch FNPT x 1/2-inch FNPT

C – Male plain end (CS is black oxide coated)

Options

- AL – Arctic Lubricant (Low Temperature Service) Not available for CS valves.
- CL – Chlorine Cleaning
- HD – Hydrostatic Testing (100%) (MSS SP-61)
- MS – Monel® Stem
- OC – Oxygen Cleaning
- PHB – Phenolic Black Handle
- PHG – Phenolic Green Handle
- PHR – Phenolic Red Handle
- PM – Panel Mount (Teflon® packed only)
- SG – (Sour Gas) meets the requirements of NACE MR0175/ISO 15156-3 Corrigendum 2 (for Chloride conditions ≤ 50 mg/l [ppm]) and NACE MR0103-2005. (SS only); (Teflon® packed only)
- SG3 – (Sour Gas) meets the requirements of NACE MR0175/ISO 15156-3 Corrigendum 2 (for Chloride conditions > 50 mg/l [ppm])
- SP – Special Requirements - please specify

Note

1. PCTFE (Polychlorotrifluoroethylene) is the exact equivalent of Kel-F®.

Block and Bleed Gauge Valves – M25 and M251

Product Overview

The M25 and M251 are two-valve single outlet gauge valves that combine isolating, calibrating, and venting facilities in a single compact unit. These valves enable gauges, pressure transmitters, or switches to be reliably installed and serviced, by reducing potential leak points.

The vent port is threaded 1/4-inch NPT on all valves and is fitted with a plug. This facilitates installation of exhaust piping/tubing on hazardous services, which in turn contributes to operator safety.

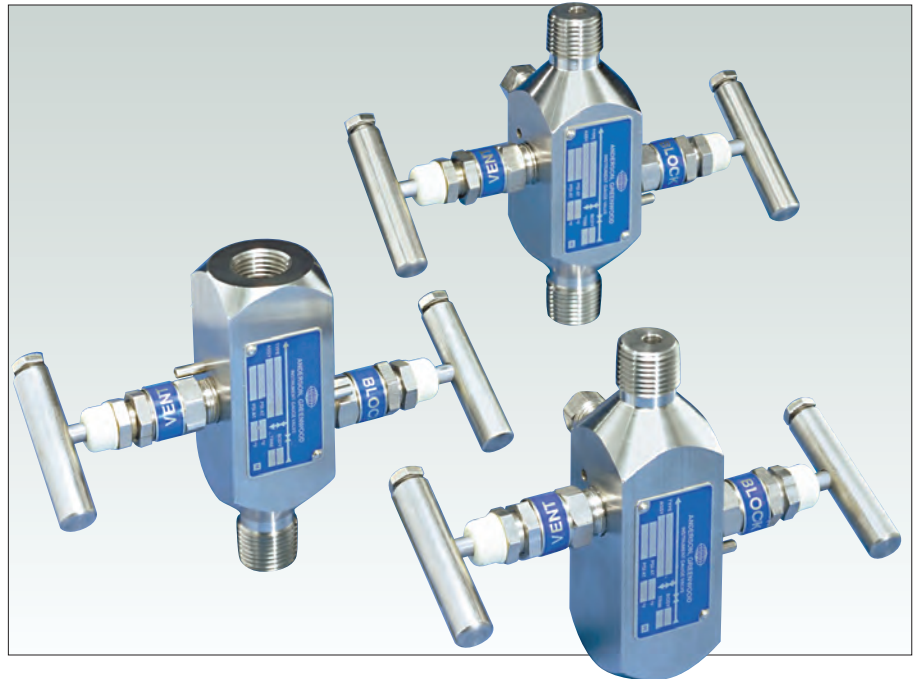

Features and Benefits

- **Compact design** requires minimum space for operation and installation. Lower valve weight increases strength at the process connection and reduces gauge whip.
- **Cost savings** from reduced number of components required for instrument installation, also decreases possible leak points.
- **Easy instrument check calibration** using 1/4-inch FNPT vent/test port.
- **Ball end stem** eliminates seat galling, provides bubble-tight shutoff and long life. The hardened, non-rotating ball ensures perfect alignment closure.
- **Packing below threads** prevents lubricant washout, thread corrosion, and keeps solids from entering the thread area, which can cause galling. It also prevents process contamination.
- **Adjustable packing** adjusts easily – loosen jam nut, tighten bushing slightly, then retighten jam nut. Decreases packing replacement downtime and increases valve life.
- **Safety back seating** prevents stem blowout or accidental removal while in operation and provides a metal-to-metal secondary stem seal while in the full open position.
- **Dust cover** prevents lubricant washout and keeps contaminants (dirt, rain, etc.) out of bonnet assembly.
- **Panel mount** (optional) affords opportunity to use high quality products in racks or panels.
- **Chrome plating of 316 SS** prevents galling or freezing of stem threads when similar metals mate. CS valves use a 303 SS stem.
- **Rolled threads** provide additional thread strength. The stem, bonnet, and male NPT threads are rolled, not cut.
- **Mirror stem finish** burnished to a 16 RMS finish in the packing area enables smooth stem operation and extends packing life.
- **Body-to-bonnet seal** is metal-to-metal in constant compression, isolating the bonnet threads from process fluid corrosion. Eliminates possible tensile breakage of bonnet, and gives a reliable seal point.
- **Bonnet lock pin** is another safety feature which prevents the accidental separation of the bonnet from the body. However, normal valve maintenance and repair are still easily accomplished.

Block and Bleed Gauge Valves – M25 and M251 Specifications

Dimensions, inches [mm]

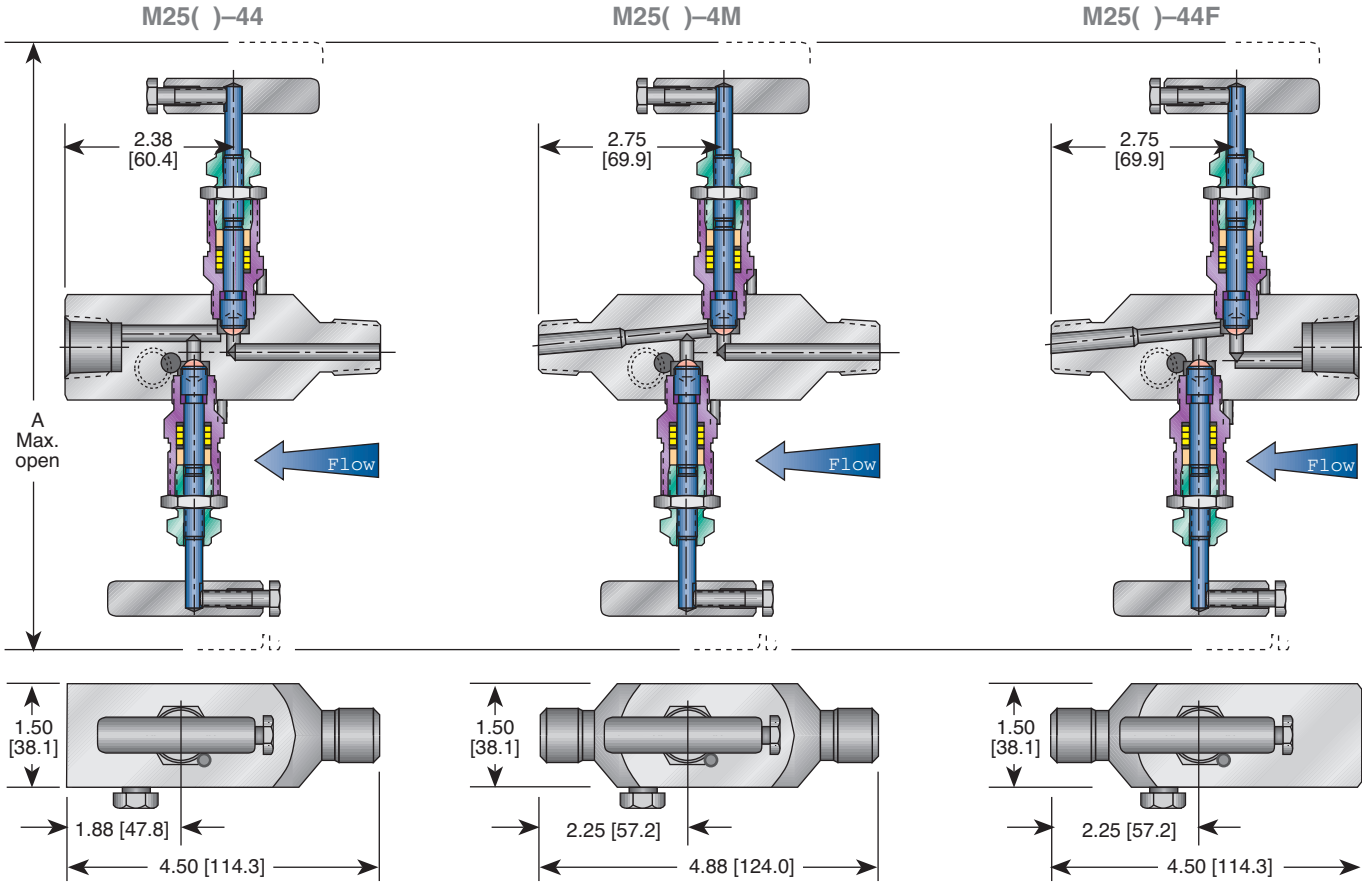

Standard Materials

Valve	Body	Bonnet	Stem	Ball	Packing
CS ¹	A105 CS	A108 CS	A581-303 SS	17-4 PH	Teflon®
CS ¹	A105 CS	A105 CS	A581-303 SS	17-4 PH	GRAFOIL® Low Emissions Graphite
SS	A479-316 SS	A479-316 SS	A276-316 SS	316 SS	Teflon®
SS	A479-316 SS	A479-316 SS	A276-316 SS	316 SS	GRAFOIL® Low Emissions Graphite
SG ²	A479-316 SS	A479-316 SS	Monel® 400	Monel® K500	Teflon®
SG ²	A479-316 SS	A479-316 SS	Monel® 400	Monel® K500	GRAFOIL® Low Emissions Graphite
SG3 ³	Hastelloy® C-276	Hastelloy® C-276	Hastelloy® C-276	Elgiloy®	Teflon®
SG3 ³	Hastelloy® C-276	Hastelloy® C-276	Hastelloy® C-276	Elgiloy®	GRAFOIL® Low Emissions Graphite

Notes

- CS is zinc-cobalt plated to prevent corrosion.
- SG (Sour Gas) meets the requirements of NACE MR0175/ISO 15156-3 Corrigendum 2 (for Chloride conditions ≤ 50 mg/l [ppm]) and NACE MR0103-2005.
- SG3 (Sour Gas) meets the requirements of NACE MR0175/ISO 15156-3 Corrigendum 2 (for Chloride conditions > 50 mg/l [ppm]).

Pressure and Temperature Ratings

Teflon® Packing

CS, SS	6000 psig @ 200°F [414 barg @ 93°C]	4000 psig @ 500°F [276 barg @ 260°C]
316L SS	5000 psig @ 200°F [345 barg @ 93°C]	
SG, SG3	6000 psig @ 200°F [414 barg @ 93°C]	4000 psig @ 500°F [276 barg @ 260°C]

GRAFOIL® and Low Emissions Graphite Packing

CS	6000 psig @ 200°F [414 barg @ 93°C]	1500 psig @ 850°F [103 barg @ 454°C]
316L SS	5000 psig @ 200°F [345 barg @ 93°C]	
SS, SG, SG3	6000 psig @ 200°F [414 barg @ 93°C]	1500 psig @ 1000°F [103 barg @ 538°C]

Block and Bleed Gauge Valves – M25 and M251 Specifications

Dimensions, inches [mm]

Packing A

Low Emissions (E)	8.14
GRAFOIL® (H)	[206.8]
Teflon® (V)	6.84
M251 only	[173.7]

Notes

1. Approximate valve weight M25()-44 and M25()-44F 3.6 lb [1.63 kg].
M25()-4M 3.8 lb [1.72 kg].
Valve C_v 0.52 maximum.
2. For Hastelloy® and SG3 call factory for dimensions and weights.

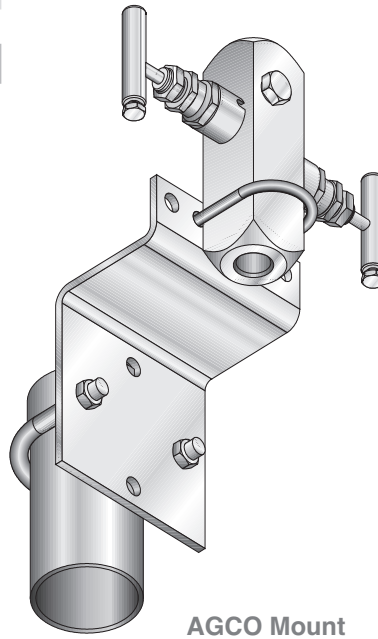
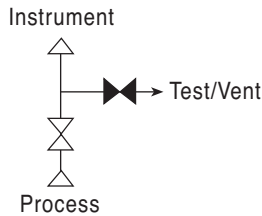

Dimensions, inches [mm]

M25()-4

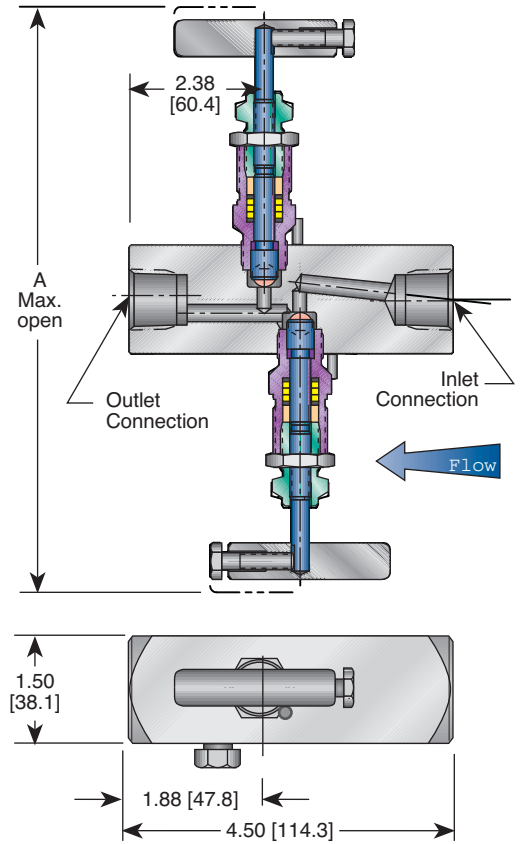

Pressure vs. Temperature – M25

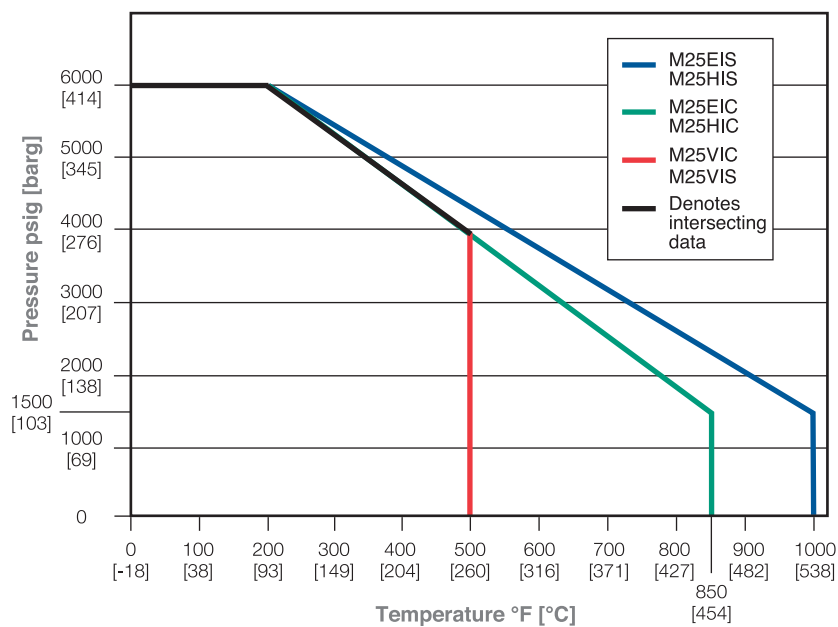

Pressure vs. Temperature – M251

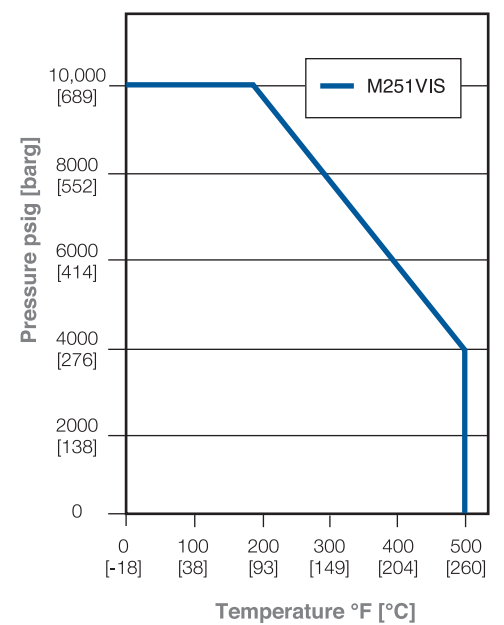

Block and Bleed Gauge Valves – M25 and M251 Specifications

Ordering Information

	M25	V	I	S	- 44C	- SG
Model Number						
	M25, M251					
Packing						
	V – Teflon®	H – GRAFOIL®	E – Low Emissions Graphite			
Seat Material						
	I – Integral					
Body Material¹						
	C – CS	S – 316 SS	M – Monel®	J – Hastelloy®	W – 316L SS (maximum pressure 5,000 psig [345 barg] @ 200°F [93°C])	
Connections (Inlet/Outlet)²						
	4M – 1/2-inch MNPT x 1/2-inch MNPT	44 – 1/2-inch MNPT x 1/2-inch FNPT	44F – 1/2-inch FNPT x 1/2-inch MNPT	46 – 3/4-inch MNPT x 1/2-inch FNPT	4 – 1/2-inch FNPT x 1/2-inch FNPT (body length 4 1/2-inch [114.5 mm])	
	C – Male plain end (CS is black oxide coated)					
Options						
	AL – Arctic Lubricant (Low Temperature Service) - not available for CS valves	AM – AGCO Mount	BL – Bonnet Lock Device (patent protected)	CL – Chlorine Cleaning	HD – Hydrostatic Testing (100%) (MSS SP-61)	OC – Oxygen Cleaning
	SG – (Sour Gas) meets the requirements of NACE MR0175/ISO 15156-3 Corrigendum 2 (for Chloride conditions ≤ 50 mg/l [ppm]) and NACE MR0103-2005 (SS only)	SG3 – (Sour Gas) meets the requirements of NACE MR0175/ISO 15156-3 Corrigendum 2 (for Chloride conditions > 50 mg/l [ppm])	SP – Special Requirements - please specify			

Notes

1. For other body materials, consult factory.
2. Consult factory for other optional connections.
3. M251 not available in GRAFOIL® or Graphite.

Block and Bleed Gauge Valves – M25 ASME B31.1 and B31.3 (meets MSS SP-105)

Ordering Information – Power Industry Applications¹

	M25 HP	S	- 44C	- XP	- AM
Model Number					
	M25 HP				
Body Material					
	S - SS, A479-316				
Connections (Inlet/Outlet)					
	4M - 1/2-inch MNPT x 1/2-inch MNPT				
	44 - 1/2-inch MNPT x 1/2-inch FNPT				
	44F - 1/2-inch FNPT x 1/2-inch MNPT				
	46 - 3/4-inch MNPT x 1/2-inch FNPT				
	4 - 1/2-inch FNPT x 1/2-inch FNPT				
	C - Male plain end (CS is black oxide coated)				
Options					
	AM - AGCO Mount				
	SP - Special Requirements - please specify				

Notes

- All Power M25 Gauge Valves come standard with GRAFOIL® packing, integral seats, bonnet locks, and are subjected to hydrostatic testing.
- SS ratings:
6000 psig @ 100°F [414 barg @ 38°C]
2915 psig @ 1000°F [201 barg @ 538°C]

Multi-Port Gauge Valves – M5 and M51

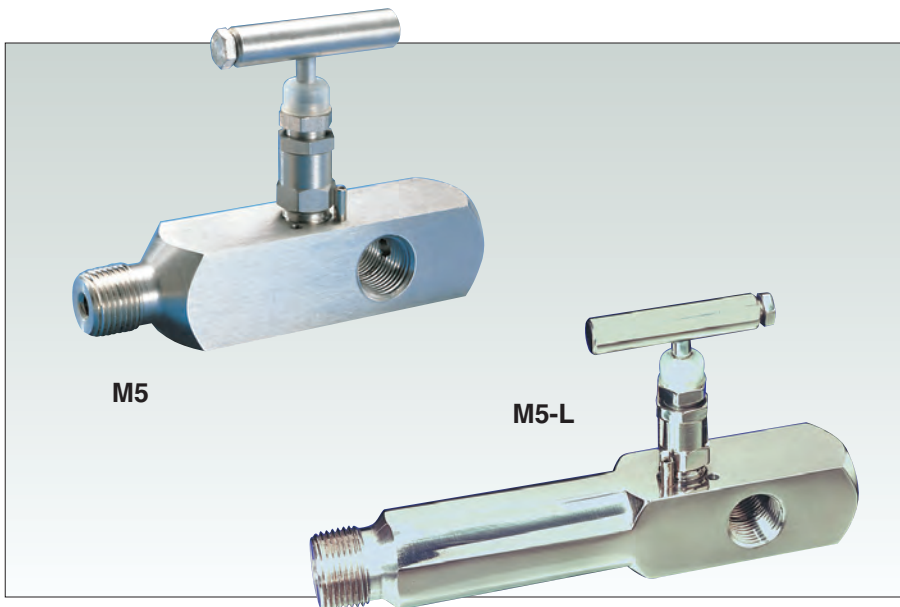

Product Overview

The M5 and M51 are multi-port gauge valves allowing the versatile positioning of gauges or pressure switches without requiring additional penetration of the main piping. For high-pressure applications, the M51 is a metal seat version of the lightweight, compact instrument isolation valve.

The standard configuration has a male or female inlet and three 1/2-inch FNPT outlet ports. All valves with male inlet connections are available threaded or prepared for welding and with either standard or extended inlets. The M5 is available with an integral metal seat or as a soft seated plug type allowing the valve to be rodded out.

Features and Benefits

- **Cost savings** are realized with multi-port design by reducing the number of components and process penetrations required for multiple instrument installations. Possible leak points are decreased.
- **Compact design** requires minimum space for operation and installation. Lower valve weight increases strength at the process connection and reduces gauge whip.
- **Long body configuration** allows for a maximum of 4-inch [102 mm] pipe insulation.
- **Roddable seat design** is supplied with replaceable seats, providing easy clean-out and seat replacement.
- **Replaceable soft seat** allows replacement of the soft seat insert without removing the valve from the line. It operates in dirty service with repetitive bubble-tight shutoff.
- **Repairable metal seat** can be resurfaced without removing the valve from the line.
- **Mirror stem finish** burnished to a 16 RMS finish in the packing area enables smooth stem operation and extends packing life.

- **Body-to-bonnet seal** is metal-to-metal in constant compression below the bonnet threads. Prevents bonnet thread corrosion, eliminates possible tensile breakage of bonnet, and gives a reliable seal point.
- **Ball end stem** eliminates seat galling, provides bubble-tight shutoff and long life. The hardened, non-rotating ball ensures perfect alignment closure.
- **Packing below threads** prevents lubricant washout, thread corrosion, and keeps solids from entering the thread area, which can cause galling. It also prevents process contamination.
- **Adjustable packing** adjusts easily – loosen jam nut, tighten bushing slightly, then retighten jam nut. Decreases packing replacement downtime and increases valve life.
- **Dust cover** prevents lubricant washout and keeps contaminants (dirt, rain, etc.) out of bonnet assembly.
- **Safety back seating** prevents stem blowout or accidental removal while in operation and provides a metal-to-metal secondary stem seal while in the full open position.
- **Chrome plating of 316 SS** prevents galling or freezing of stem threads when similar metals mate. CS valves use a 303 SS stem.
- **Rolled threads** provide additional thread strength. The stem, bonnet, and male NPT threads are rolled, not cut.
- **Bonnet lock pin** is another safety feature which prevents the accidental separation of the bonnet from the body. However, normal valve maintenance and repair are still easily accomplished.

Multi-Port Gauge Valves – M5 and M51 Specifications³

Notes

- M5 metal seat only.
- Approximate valve weight:
 - standard 2.5 lb [1.1 kg].
 - long 3.0 lb [1.4 kg].
 Orifice Size: 0.187-inch [4.8 mm] diameter.
 Valve C_v 0.523 maximum.
 Long body length 7.25-inch [184.2 mm] for
 4-inch [102.0 mm] insulation.
- For Hastelloy® and SG3 call factory for
 dimensions and weights.

M5 and M51 Metal Seat Dimensions, inches [mm]

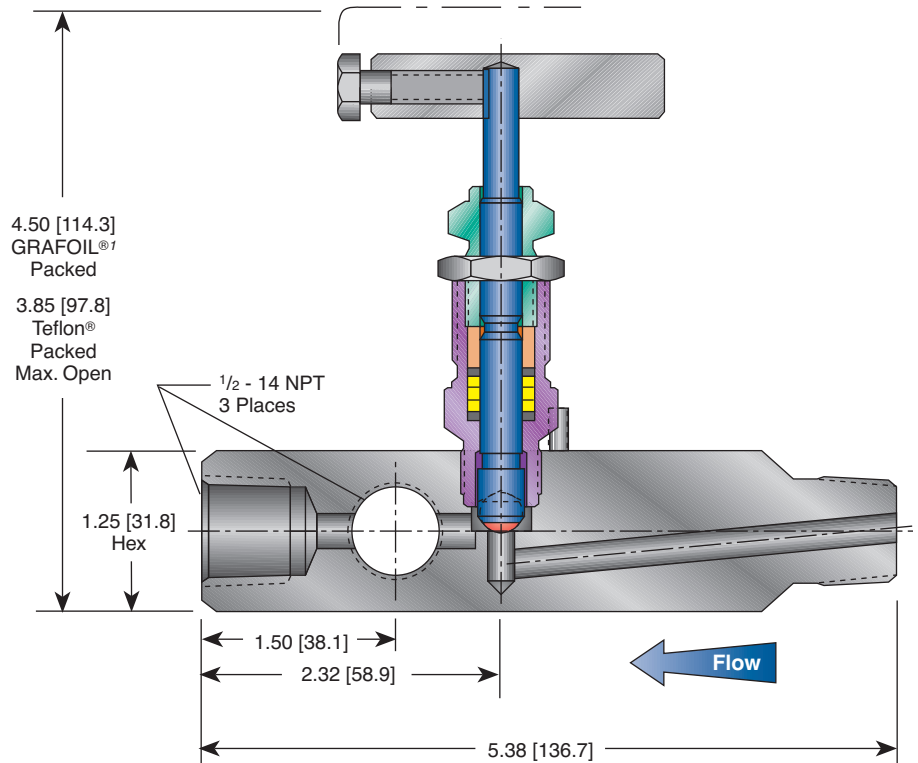

Notes

- Approximate valve weight:
 - standard 2.5 lb [1.1 kg].
 Orifice Size: 0.187-inch [4.8 mm] diameter.
 Valve C_v 0.83 maximum.
- For Hastelloy® and SG3 call factory for
 dimensions and weights.

M5 Soft Seat Dimensions, inches [mm]

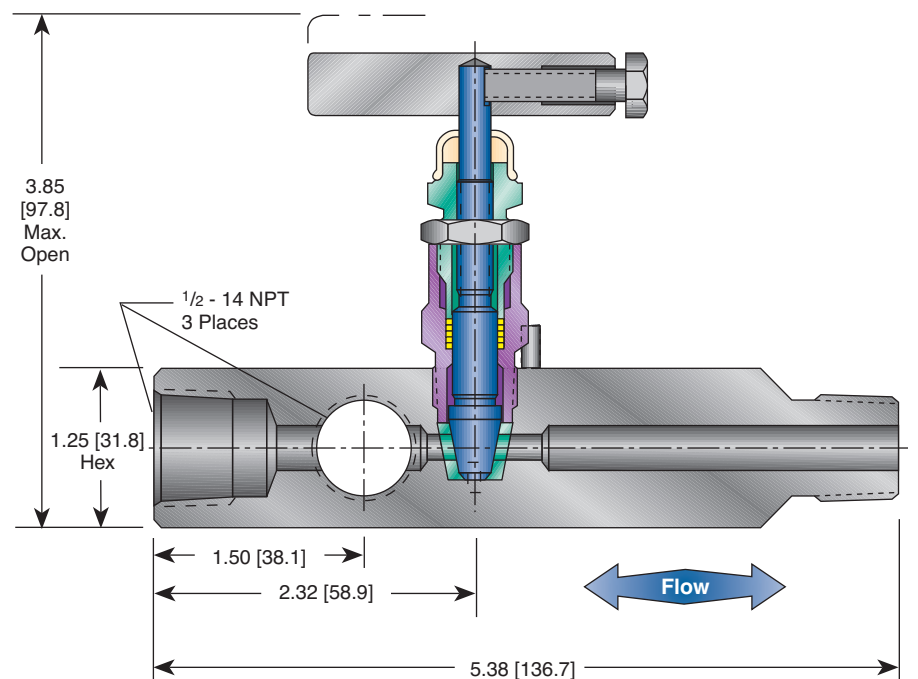

Multi-Port Gauge Valves – M5 and M51 Specifications

Standard Materials

M5 Metal Seat

Valve	Body	Bonnet	Stem	Ball	Packing
CS ¹	A105 CS	A105 CS	A581 303 SS	17-4 PH	GRAFOIL®, Low Emission Graphite
CS ¹	A105 CS	A108 CS	A581 303 SS	17-4 PH	Teflon®
SS	A479 316 SS	A479 316 SS	A276 316 SS	316 SS	GRAFOIL®, Low Emission Graphite
SS	A479 316 SS	A479 316 SS	A276 316 SS	316 SS	Teflon®
Monel®	Monel® R405	Monel® R405	Monel® 400	Monel® K500	Teflon®
SG ²	A479 316 SS	A479 316 SS	Monel® 400	Monel® K500	GRAFOIL®, Low Emission Graphite
SG ²	A479 316 SS	A479 316 SS	Monel® 400	Monel® K500	Teflon®
SG3 ⁵	Hastelloy® C-276	Hastelloy® C-276	Hastelloy® C-276	Elgiloy®	GRAFOIL®, Low Emission Graphite
SG3 ⁵	Hastelloy® C-276	Hastelloy® C-276	Hastelloy® C-276	Elgiloy®	Teflon®

M51 Metal Seat

Valve	Body	Bonnet	Stem	Ball
SS	A479 316 SS	A479 316 SS	A276 316 SS	A151 316 SS
SG ²	A479 316 SS	A479 316 SS	Monel® 400	Monel® K500
SG3 ⁵	Hastelloy® C-276	Hastelloy® C-276	Hastelloy® C-276	Elgiloy®

M5 Soft Seat

Valve	Body	Bonnet	Stem	Packing	Seat ³
CS ¹	A108 CS	A108 CS	A581 303 SS	Teflon®	Delrin®
SS	A479 316 SS	A479 316 SS	A276 316 SS	Teflon®	Elgiloy®
Monel®	Monel® R405	Monel® R405	Monel® 400	Teflon®	PCTFE ⁴
SG ²	A479 316 SS	A479 316 SS	Monel® 400	Teflon®	Delrin®
SG3 ⁵	Hastelloy® C-276	Hastelloy® C-276	Hastelloy® C-276	Teflon®	Delrin®

Pressure and Temperature Ratings

M5 Metal Seat

Valve	Packing	Ratings
CS	GRAFOIL®, Low Emission Graphite	6000 psig @ 200°F [414 barg @ 93°C] 1500 psig @ 850°F [103 barg @ 454°C]
SS, SG, SG3	GRAFOIL®, Low Emission Graphite	6000 psig @ 200°F [414 barg @ 93°C] 1500 psig @ 1000°F [103 barg @ 454°C]
CS, SS, Monel®, SG, SG3	Teflon®	6000 psig @ 200°F [414 barg @ 93°C] 4000 psig @ 500°F [276 barg @ 260°C]

M51 Metal Seat

CS, SS, SG, SG3	Teflon®	10,000 psig @ 200°F [689 barg @ 93°C] 4000 psig @ 500°F [276 barg @ 260°C]
-----------------	---------	---

M5 Soft Seat

CS, SS, Monel®, SG, SG3	Teflon®	6000 psig @ 200°F [414 barg @ 93°C]
-------------------------	---------	-------------------------------------

Notes

1. CS is zinc-cobalt plated to prevent corrosion. Plain end valves are black oxide coated.
2. SG (Sour Gas) meets the requirements of NACE MR0175/ISO 15156-3 Corrigendum 2 (for Chloride conditions ≤ 50 mg/l [ppm]) and NACE MR0103-2005.
3. PEEK and Teflon® also available.
4. PCTFE (Polychlorotrifluoroethylene) is the exact equivalent of Kel-F®.
5. SG3 (Sour Gas) meets the requirements of NACE MR0175/ISO 15156-3 Corrigendum 2 (for Chloride conditions > 50 mg/l [ppm]).
6. Elgiloy® is a registered trademark of Elgiloy Specialty Metals.

Multi-Port Gauge Valves – M5 and M51 Specifications

Pressure vs. Temperature¹ – M5 and M51 Metal Seat

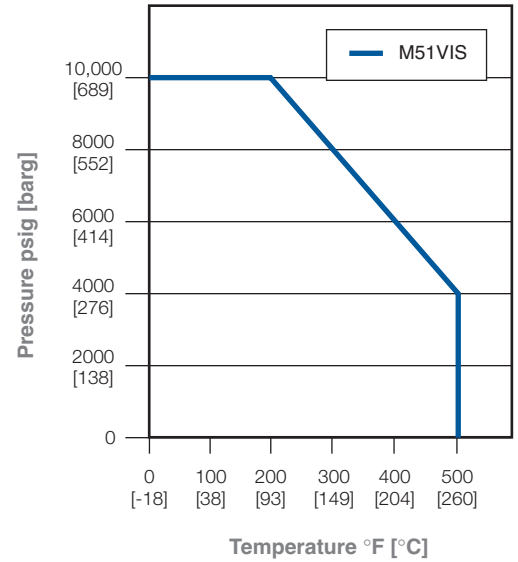
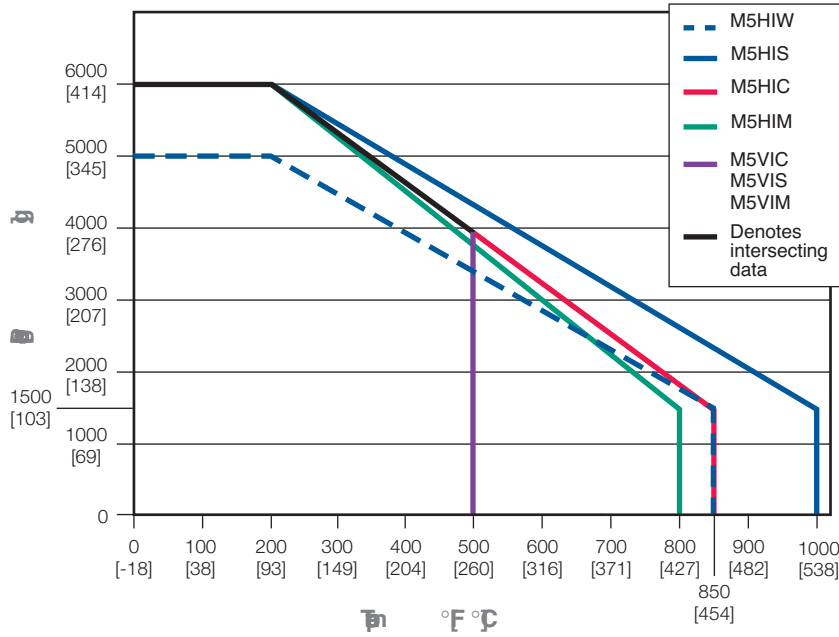

Pressure vs. Temperature – M5 Soft Seat

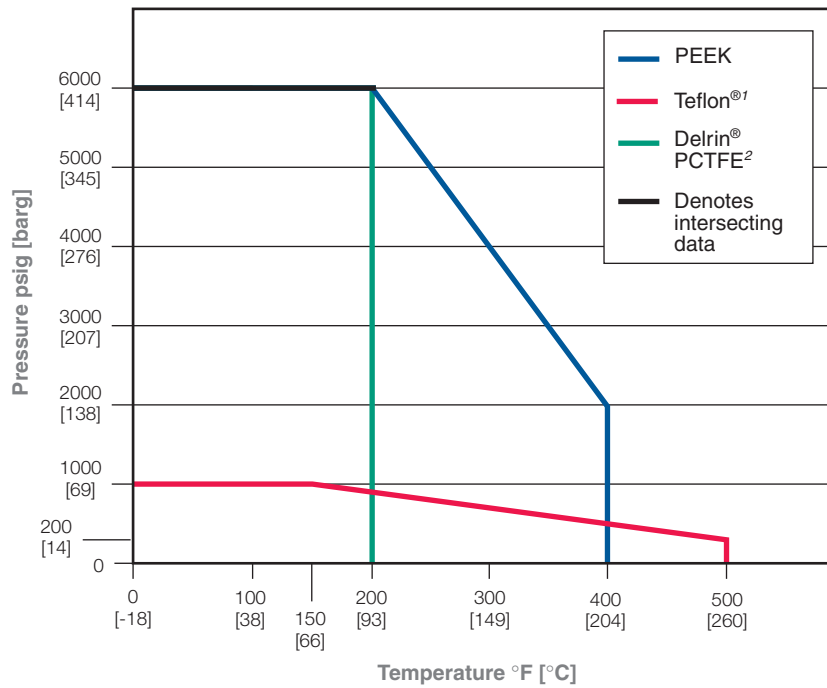

Notes

- O-ring packed soft seat valve 400°F [204°C] maximum.
- PCTFE (Polychlorotrifluoroethylene) is the exact equivalent of Kel-F®.

Multi-Port Gauge Valves – M5 Metal Seat Specifications

Ordering Information – Metal Seat

M5 H I S – 44L –SG

Packing

- H – GRAFOIL®
- V – Teflon®
- E – Low Emission Graphite

Seat

- I – Integral

Body Material¹

- C – CS, A105
- S – SS, A479-316
- M – Monel®
- W – 316L
- J – Hastelloy®

Connections (Inlet/Outlet)¹

- 44 – 1/2-inch MNPT x (3) 1/2-inch FNPT
- 46 – 3/4-inch MNPT x (3) 1/2-inch FNPT
- C – Male plain end (CS is black oxide coated)
- L – Long body extension (4-inch insulation)

Options

- AL – Arctic Lubricant (Low Temperature Service) - not available for CS valves
- BL – Bonnet Lock Device (patent protected)
- CL – Chlorine Cleaning
- HD – Hydrostatic Testing (100%)(MSS MSP-61)
- OC – Oxygen Cleaning
- SG – (Sour Gas) meets the requirements of NACE MR0175/ISO 15156-3 Corrigendum 2 (for Chloride conditions ≤ 50 mg/l [ppm]) and NACE MR0103-2005 (SS only)
- SG3 – (Sour Gas) meets the requirements of NACE MR0175/ISO 15156-3 Corrigendum 2 (for Chloride conditions > 50 mg/l [ppm]) - if accessories are added, consult factory for materials
- SP – Special Requirements - please specify

Note

1. Call factory for optional material, other sizes, or end connections.

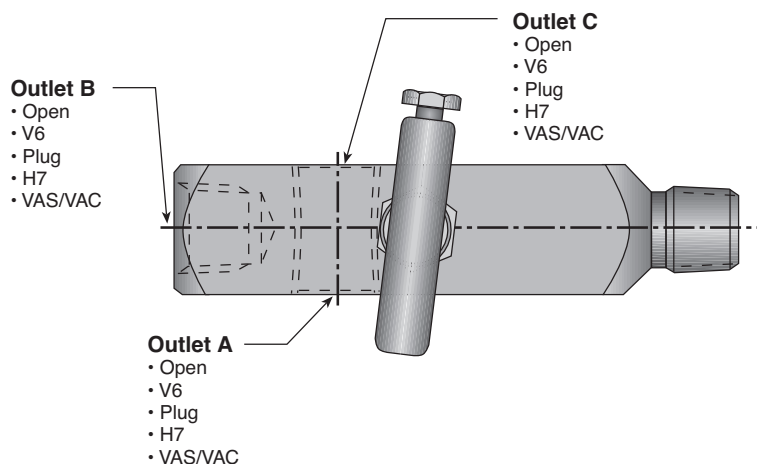

Multi-Port Gauge Valves – M5 Soft Seat Specifications

Notes

1. PCTFE (Polychlorotrifluoroethylene) is the exact equivalent of Kel-F®.
2. Call factory for optional materials, other sizes, or end connections.
3. Temperature limited to seat materials.
4. Bonnet lock not available.

Ordering Information – Soft Seat

M5

V

D

S

- 44L

-SG

Packing

- V – Teflon®
- R – Viton® O-ring
- E – Low emissions Graphite³

Seat

- V – Teflon®
- D – Delrin® (standard)
- E – PEEK
- K – PCTFE¹

Body Material²

- C – CS, A108
- S – SS, A479-316
- M – Monel®
- W – 316L
- J – Hastelloy®⁴

Connections (Inlet/Outlet)²

- 44 – 1/2-inch MNPT x (3) 1/2-inch FNPT
- 46 – 3/4-inch MNPT x (3) 1/2-inch FNPT
- C – Male plain end (CS is black oxide coated)
- L – Long body extension (4-inch insulation)

Options

- AL – Arctic Lubricant (Low Temperature Service) - not available for CS valves
- BL – Bonnet Lock Device (patent protected)
- CL – Chlorine Cleaning
- HD – Hydrostatic Testing (100%)(MSS MSP-61)
- OC – Oxygen Cleaning
- SG – (Sour Gas) meets the requirements of NACE MR0175/ISO 15156-3 Corrigendum 2 (for Chloride conditions ≤ 50 mg/l [ppm]) and NACE MR0103-2005 (SS only)
- SG3 – (Sour Gas) meets the requirements of NACE MR0175/ISO 15156-3 Corrigendum 2 (for Chloride conditions > 50 mg/l [ppm]) - if accessories are added, consult factory for materials
- SP – Special Requirements - please specify

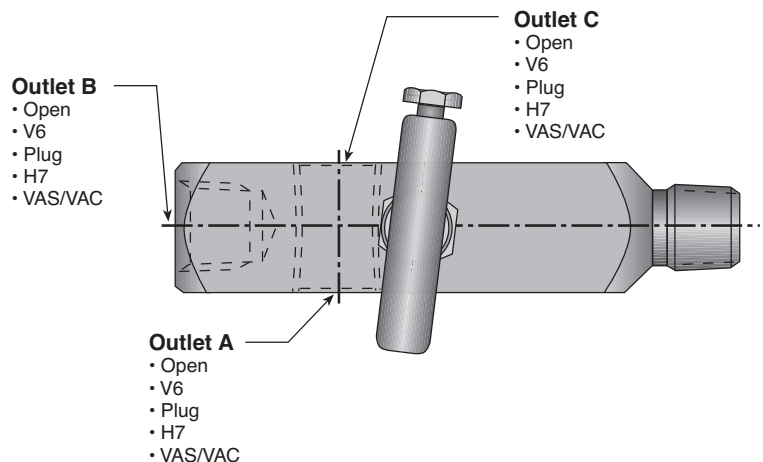

Multi-Port Gauge Valves – M5 ASME B31.1 and B31.3 Specifications Meets MSS SP-105

Ordering Information – Power Industry Applications¹

M5HP S – 44LC – XP – SP

Body Material

- C – CS, A105
- S – SS, A479-316

Connections (Inlet/Outlet)

- 44 – 1/2-inch MNPT x (3) 1/2-inch FNPT
- 46 – 3/4-inch MNPT x (3) 1/2-inch FNPT

- C – Male plain end (CS is black oxide coated)
- L – Long body (4-inch insulation)

Options

SP – Special Requirements - please specify

Note

- All Power M5 Gauge Valves come standard with GRAFOIL® packing, integral seats, bonnet locks, and are subjected to hydrostatic testing.

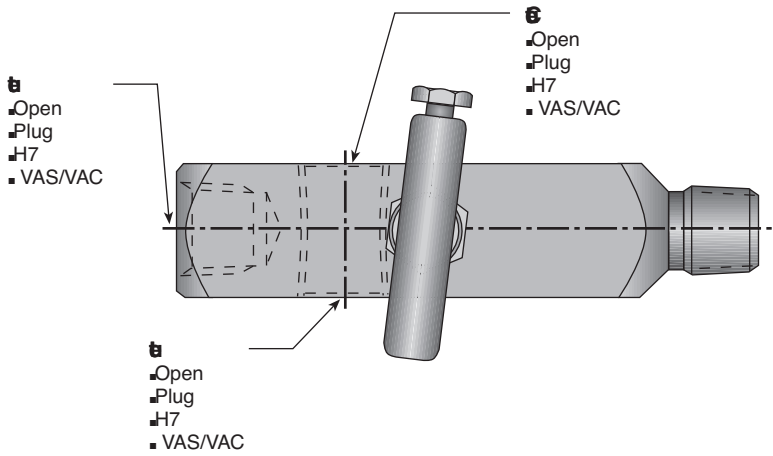

Multi-Port Gauge Valves – M51 10,000 psi Specifications

Note

1. Call factory for optional materials, other sizes, or end connections.

Ordering Information

M51 V I S – 44LC – SG

Packing

V – Teflon®
Not available in GRAFOIL®

Seat

I – Integral

Body Material¹

S – SS, A479-316
J – Hastelloy®

Connections (Inlet/Outlet)¹

44 – 1/2-inch MNPT x (3) 1/2-inch FNPT
46 – 3/4-inch MNPT x (3) 1/2-inch FNPT

C – Male plain end (CS is black oxide coated)
L – Long body extension (4-inch insulation)

Options

- AL – Arctic Lubricant (Low Temperature Service) - not available for CS valves
- CL – Chlorine Cleaning
- HD – Hydrostatic Testing (100%) (MSS MSP-61)
- OC – Oxygen Cleaning
- SG – (Sour Gas) meets the requirements of NACE MR0175/ISO 15156-3 Corrigendum 2 (for Chloride conditions ≤ 50 mg/l [ppm]) and NACE MR0103-2005 (SS only)
- SG3 – (Sour Gas) meets the requirements of NACE MR0175/ISO 15156-3 Corrigendum 2 (for Chloride conditions > 50 mg/l [ppm]) - if accessories are added, consult factory for materials
- SP – Special Requirements - please specify

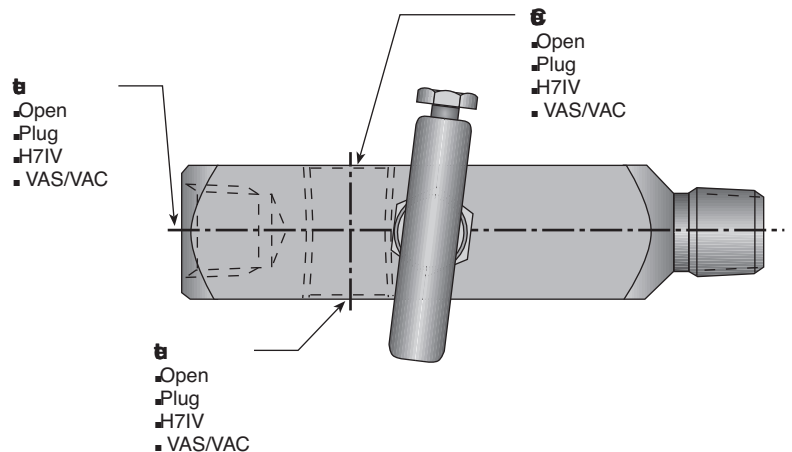

Multi-Port Gauge Valves – M5A

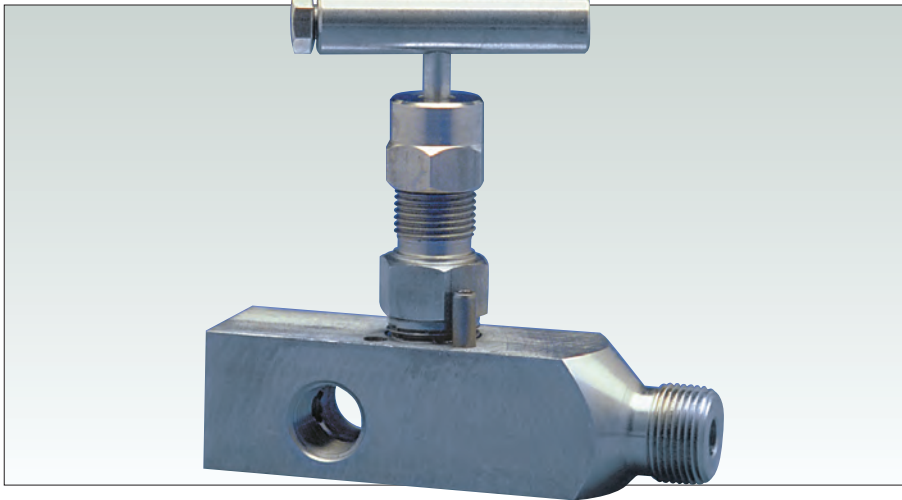

Product Overview

The M5A gauge valve is a $\frac{3}{8}$ -inch [9.5 mm] orifice multi-port gauge valve. It is designed to be used with gauge mounting and other instrument tie-ins in the process industries, without requiring additional penetrations of the main piping. The M5A provides premium performance and long valve life.

This valve is available with replaceable, roddable, metal or soft seats with $\frac{3}{8}$ -inch [9.5 mm] diameter orifice. The unique metal seat design, an exclusive feature of Anderson Greenwood, offers bubble-tight shutoff with straight-through flow characteristics.

Features and Benefits

- **Cost savings;** multi-port outlet reduces the number of components required for instrument installation while decreasing possible leak points.
- **Compact design** requires minimum space for operation and installation. Lower valve weight increases strength at the process connection and reduces gauge whip.
- **Unique metal seat** has straight-through flow path design for reduced plugging in high-temperature service.
- **Long body configuration** allows for a maximum of 4-inch [102 mm] pipe insulation.
- **Roddable seat design** is supplied with replaceable seats, providing easy clean-out and seat replacement.
- **Replaceable soft seat** allows replacement of the soft seat insert without removing the valve from the line. It operates in dirty service with repetitive bubble-tight shutoff.
- **Mirror stem finish** burnished to a 16 RMS finish in the packing area enables smooth stem operation and extends packing life.
- **Body-to-bonnet seal** is metal-to-metal in constant compression below the bonnet threads. Prevents bonnet thread corrosion, eliminates possible tensile breakage of bonnet, and gives a reliable seal point.

- **Adjustable packing** adjusts easily by tightening the packing nut slightly. Decreases packing replacement downtime and increases valve life.
- **Safety back seating** prevents stem blowout or accidental removal while in operation.
- **Chrome plating of 316 SS** prevents galling or freezing of stem threads when similar metals mate. CS valves use a 303 SS stem.
- **Rolled threads** provide additional thread strength. The stem, bonnet, and male NPT threads are rolled, not cut.
- **Bonnet lock pin** is another safety feature which prevents the accidental separation of the bonnet from the body. However, normal valve maintenance and repair are still easily accomplished.

Multi-Port Gauge Valves – M5A Specifications

Dimensions, inches [mm]

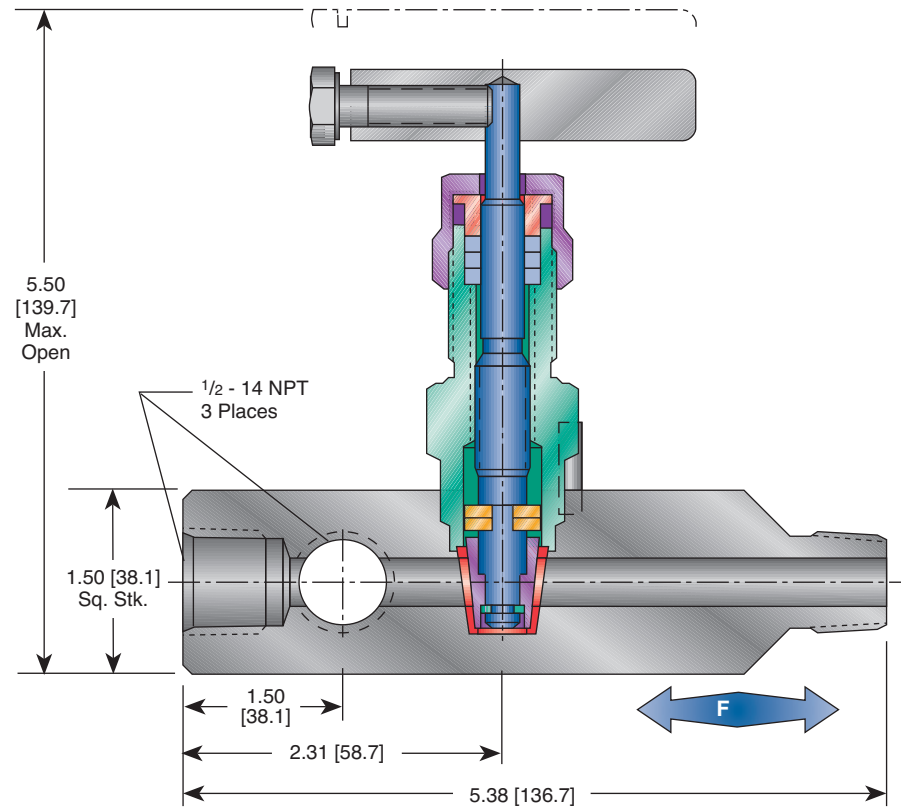

Notes

1. CS is zinc-cobalt plated to prevent corrosion.
2. SG (Sour Gas) meets the requirements of NACE MR0175/ISO 15156-3 Corrigendum 2 (for Chloride conditions ≤ 50 mg/l [ppm]) and NACE MR0103-2005.
3. SG3 (Sour Gas) meets the requirements of NACE MR0175/ISO 15156-3 Corrigendum 2 (for Chloride conditions > 50 mg/l [ppm]).

Standard Materials – Metal and Soft Seats

Valve	Body	Stem	Bonnet
CS ¹	A105 CS	A582-303 SS	A108 CS
316 SS	A479-316 SS	A276-316 SS	A479-316 SS
316L SS	A479-316L SS	A276-316 SS	A479-316 SS
SG ²	A479-316 SS	Monel® R405	A479-316 SS
Monel®	Monel® 400	Monel® R405	Monel® R405
SG3 ³	Hastelloy® C-276	Hastelloy® C-276	Hastelloy® C-276

Pressure and Temperature Ratings

Metal Seat

Teflon® packed	1500 psig @ 500°F	[103 barg @ 260°C]
GRAFOIL® packed	1500 psig @ 850°F	[103 barg @ 454°C]

Soft Seat

Delrin	6000 psig @ 200°F	[414 barg @ 93°C]
PCTFE (Kel-F®)	5000 psig @ 200°F	[345 barg @ 93°C]
PEEK	6000 psig @ 200°F	[414 barg @ 93°C]
	2000 psig @ 400°F	[138 barg @ 204°C]
Teflon®	1000 psig @ 150°F	[69 barg @ 66°C]
	200 psig @ 500°F	[14 barg @ 260°C]

Multi-Port Gauge Valves – M5A Specifications

Pressure vs. Temperature – Metal Seat

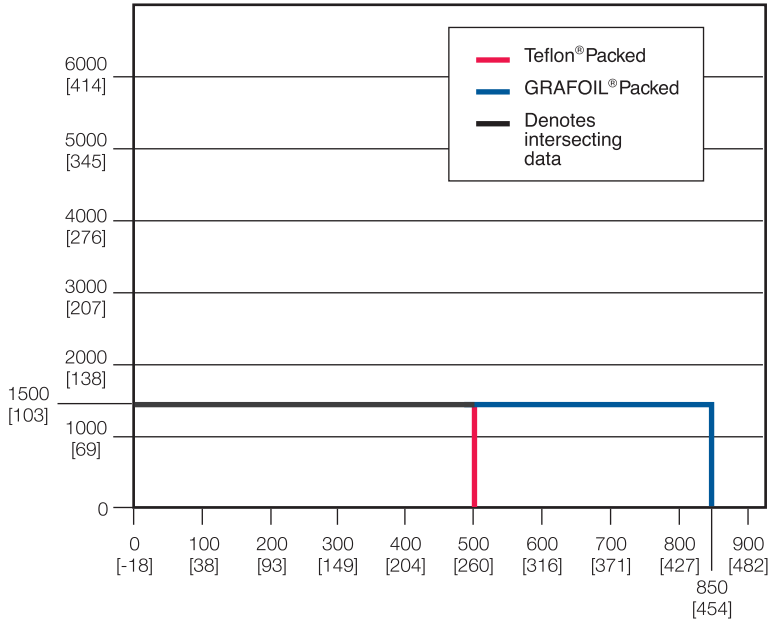

Pressure vs. Temperature – Soft Seat

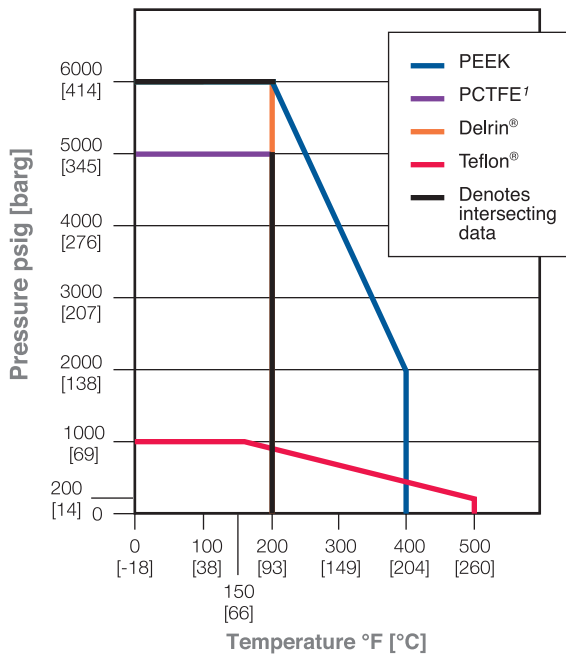

Note

1. PCTFE (Polychlorotrifluoroethylene) is the exact equivalent of Kel-F®.

Multi-Port Gauge Valves – M5A Metal Seat Specifications

Ordering Information – Metal Seat

	M5A	H	S	S	- 44L	- SG
Packing						
	H – GRAFOIL® V – Teflon®					
Seat						
	S – 316 SS (standard) M – Monel®					
Body Material						
	C – CS, A105 S – SS, A479-316 M – Monel® 400 W – SS, A479-316L J – Hastelloy®					
Connections (Input/Output)						
	44 – 1/2-inch MNPT x (3) 1/2-inch FNPT 46 – 3/4-inch MNPT x (3) 1/2-inch FNPT C – Male socket weld L – Long body (7.75-inch [196.8 mm])					

Options

- AL – Arctic Lubricant (Low Temperature Service) - not available for CS valves
- BL – Bonnet Lock Device (patent protected)
- CL – Chlorine Cleaning
- HD – Hydrostatic Testing (100%) (MSS SP-61)
- OC – Oxygen Cleaning
- SG – (Sour Gas) meets the requirements of NACE MR0175/ISO 15156-3 Corrigendum 2 (for Chloride conditions ≤ 50 mg/l [ppm]) and NACE MR0103-2005 (SS only)
- SG3 – (Sour Gas) meets the requirements of NACE MR0175/ISO 15156-3 Corrigendum 2 (for Chloride conditions > 50 mg/l [ppm]) - if accessories are added, consult factory for materials
- SP – Special Requirements - please specify

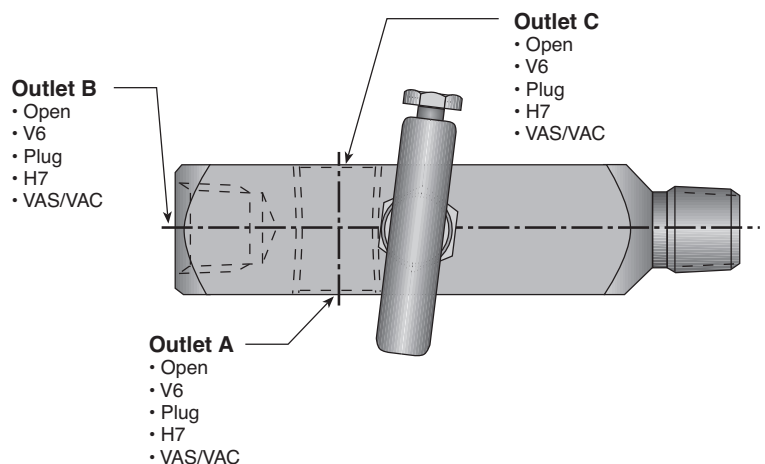

Multi-Port Gauge Valves – M5A Soft Seat Specifications

Ordering Information – Soft Seat

M5A **V** **D** **S** **- 44L** **- SG**

Packing

V – Teflon®

Seat

V – Teflon® E – PEEK
D – Delrin® (standard) K – PCTFE'

Body Material

C – CS, A105
S – SS, A479-316 SS
M – Monel® 400
W – SS, A479-316L
J – Hastelloy®

Connections (Input/Output)

44 – 1/2-inch MNPT x (3) 1/2-inch FNPT
46 – 3/4-inch MNPT x (3) 1/2-inch FNPT

C – Male socket weld
L – Long body (7.75-inch [196.8 mm])

Options

- AL – Arctic Lubricant (Low Temperature Service) - not available for CS valves
- BL – Bonnet Lock Device (patent protected)
- CL – Chlorine Cleaning
- HD – Hydrostatic Testing (100%) (MSS SP-61)
- OC – Oxygen Cleaning
- SG – (Sour Gas) meets the requirements of NACE MR0175/ISO 15156-3 Corrigendum 2 (for Chloride conditions ≤ 50 mg/l [ppm]) and NACE MR0103-2005 (SS only)
- SG3 – (Sour Gas) meets the requirements of NACE MR0175/ISO 15156-3 Corrigendum 2 (for Chloride conditions > 50 mg/l [ppm]) - if accessories are added, consult factory for materials
- SP – Special Requirements - please specify

Note

1. PCTFE (Polychlorotrifluoroethylene) is the exact equivalent of Kel-F®.

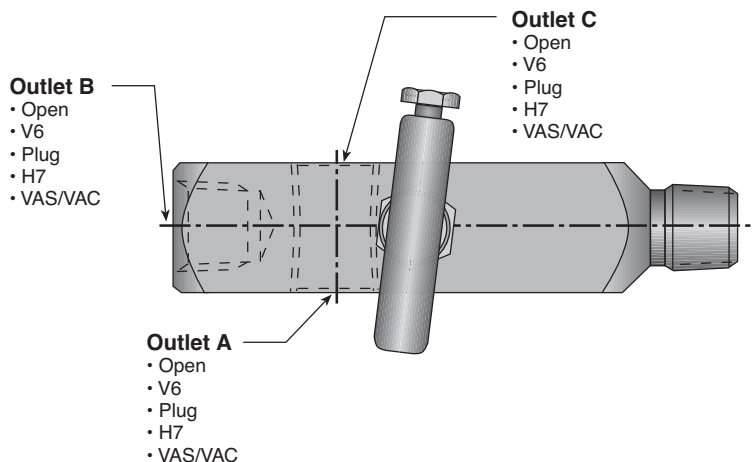

Multi-Port Gauge Valves – M5F

Product Overview

The M5F gauge valve is a 1/4-inch FNPT x (3) 1/4-inch FNPT multi-port valve for universal use wherever more than one outlet is required. The valve features a field replaceable soft seat that ensures repeatable bubble-tight closure and a long, trouble-free life.

A typical application for this valve is in the double-block and bleed assembly in natural gas piped five-valve manifolds for recording orifice meter service, and a 1/4-inch gauge valves where bleed-off or sampling valves are needed in the same installation.

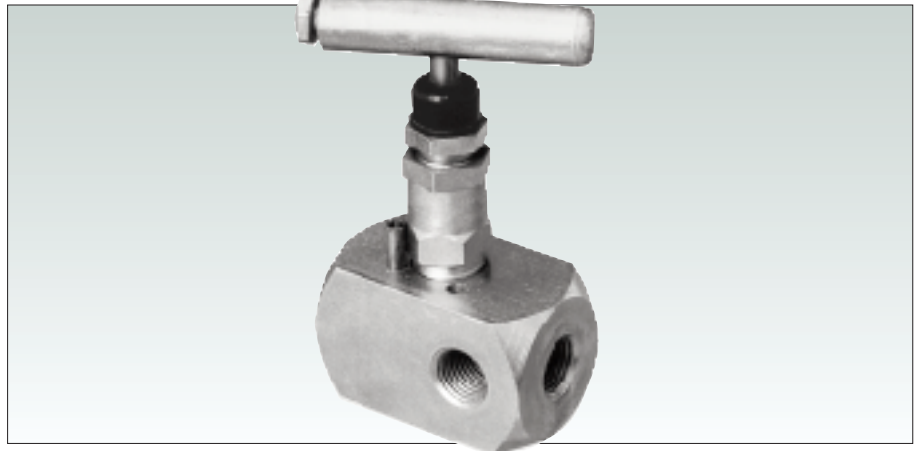

Features and Benefits

- **Bonnet-to-body seal** is metal-to-metal in constant compression, below the bonnet threads. This prevents process bonnet thread corrosion, eliminates possible tensile breakage of bonnet, and gives a reliable seal point.
- **Rolled stem and bonnet threads** are rolled (rather than cut), providing extra thread strength.
- **Dust cover** protects stem from lubricant contamination.
- **Packing below stem threads** prevents lubricant washout and thread corrosion. Keeps solids from entering the thread area, which can cause galling. Also prevents process contamination/corrosion.
- **Replaceable soft seat** allows replacement of the seat insert without removing the valve from the line. Operates in dirty service with repetitive bubble-tight shutoff.
- **Teflon® packing** is easily adjusted by loosening the jam nut, tightening the bushing slightly, then re-tightening the jam nut. This feature reduces downtime and ensures long valve life.
- **Mirror finished stem** is burnished to a 16 RMS finish in the packing area. This provides smooth stem operation and increases packing life.
- **Safety back seating** prevents stem blowout and accidental removal while in operation. This feature also provides a metal-to-metal secondary stem seal while in the full open position.
- **Straight-through flow path** means high flow capacity, bi-directional flow, and rodding capabilities.

Multi-Port Gauge Valve – M5F Specifications⁵

Dimensions, inches [mm]

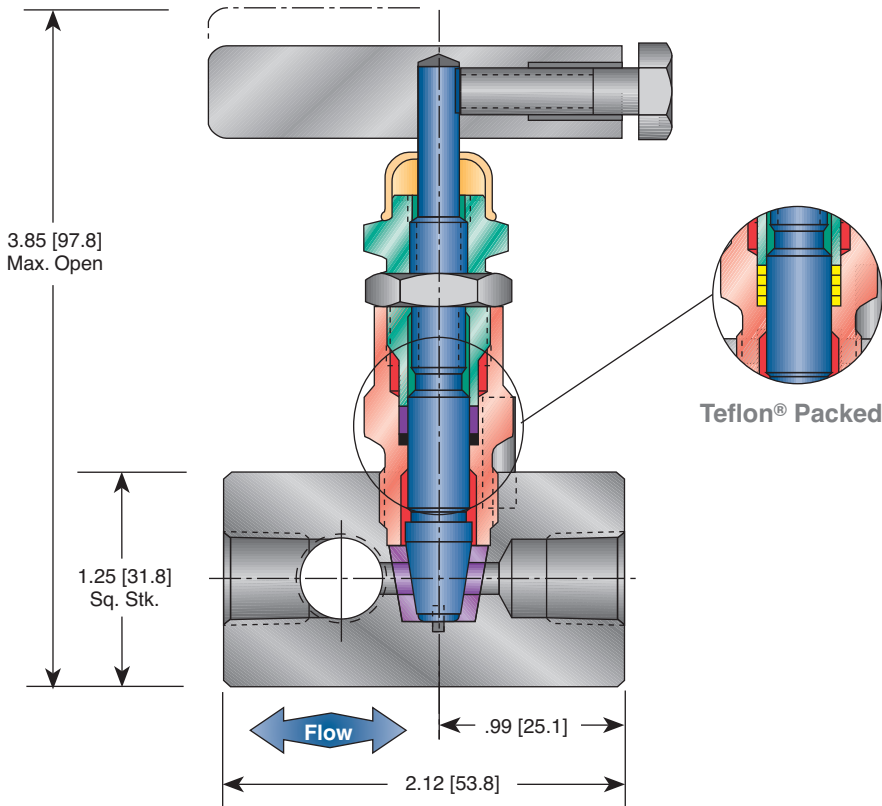

Standard Materials

Valve ¹	Body and Bonnet	Stem	Stem Seal	Seat
CS ²	A108 CS	A581-303 SS	Viton® or Teflon®	Delrin®
SS	A479-316 SS	A276-316 SS	Viton® or Teflon®	Delrin®
SG ⁶	A479-316 SS	Monel® 400	Teflon®	Delrin®
SG3 ⁷	Hastelloy® C-276	Hastelloy® C-276	Teflon®	Delrin®

Pressure and Temperature Ratings

Valve	Packing ³	Seat	Ratings	
CS ² , SS, SG3	Viton® or Teflon®	Delrin®/PCTFE ⁴	6000 psig @ 200°F	[414 barg @ 93°C]
CS ² , SS, SG3	Viton® or Teflon®	PEEK	6000 psig @ 200°F 2000 psig @ 400°F	[414 barg @ 93°C] [138 barg @ 204°C]
CS ² , SS, SG3	Viton® or Teflon®	Teflon®	1000 psig @ 150°F 200 psig @ 500°F	[69 barg @ 66°C] [14 barg @ 260°C]

Notes

- Approximate valve weight:
- standard 1.0 lb [0.5 kg].
Orifice Size: 0.187-inch [4.8 mm] diameter.
Valve C_v 0.83 maximum.
- CS body and bonnet are zinc-cobalt plated to prevent corrosion.
- O-ring packed maximum temperature 400°F [204°C].
- PCTFE (Polychlorotrifluoroethylene) is the exact equivalent of Kel-F®.
- For Hastelloy® and SG3 call factory for dimensions and weights.
- SG (Sour Gas) meets the requirements of NACE MR0175/ISO 15156-3 Corrigendum 2 (for Chloride conditions ≤ 50 mg/l [ppm]) and NACE MR0103-2005.
- SG3 (Sour Gas) meets the requirements of NACE MR0175/ISO 15156-3 Corrigendum 2 (for Chloride conditions > 50 mg/l [ppm]).

Multi-Port Gauge Valve – M5F Specifications

Notes

1. PCTFE (Polychlorotrifluoroethylene) is the exact equivalent of Kel-F®.
2. O-ring packed maximum temperature 400°F [204°C].
3. CS is zinc-cobalt plated to prevent corrosion.

Pressure vs. Temperature

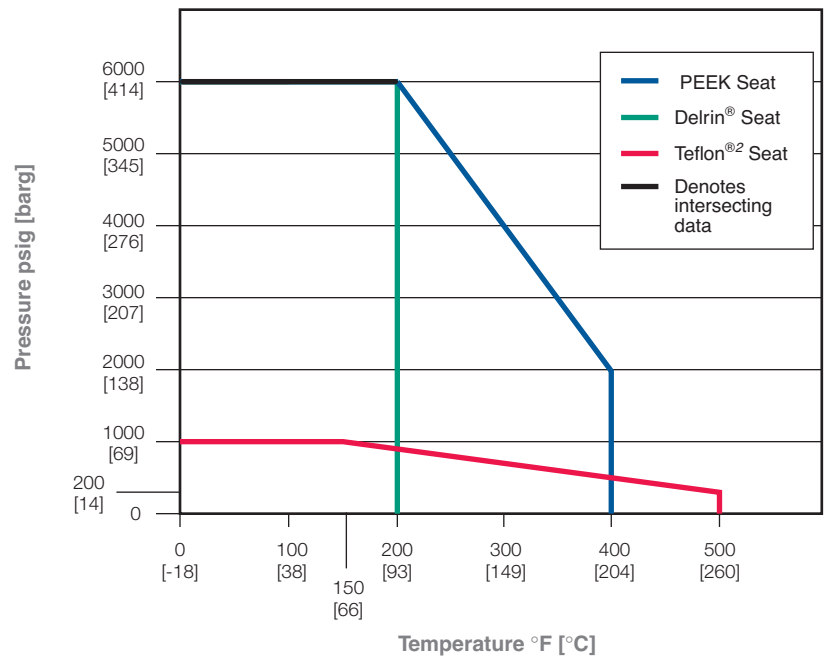

Ordering Information

M5F **V** **D** **S** **- 2** **- SG**

Packing

- V – Teflon®
- R – O-ring with Teflon® Backup

Seat

- D – Delrin® (standard)
- K – PCTFE¹
- E – PEEK
- V – Teflon®

Body

- C – CS³
- S – 316 SS
- J – Hastelloy®

Connections (Inlet/Outlet)

- 2 – 1/4-inch FNPT x (3) 1/4-inch FNPT

Options

- BL – Bonnet Lock Device (patent protected)
- CL – Chlorine Cleaning
- HD – Hydrostatic Testing (100%)(MSS SP-61)
- OC – Oxygen Cleaning
- SG – (Sour Gas) meets the requirements of NACE MR0175/ISO 15156-3 Corrigendum 2 (for Chloride conditions ≤ 50 mg/l [ppm]) and NACE MR0103-2005 (SS only)
- SG3 – (Sour Gas) meets the requirements of NACE MR0175/ISO 15156-3 Corrigendum 2 (for Chloride conditions > 50 mg/l [ppm]) - if accessories are added, consult factory for materials

OS&Y Root Valves – M5K, M5AK, and M5YK

Root Isolation Valves with Outside Screw and Yoke, Bolted Bonnet Construction

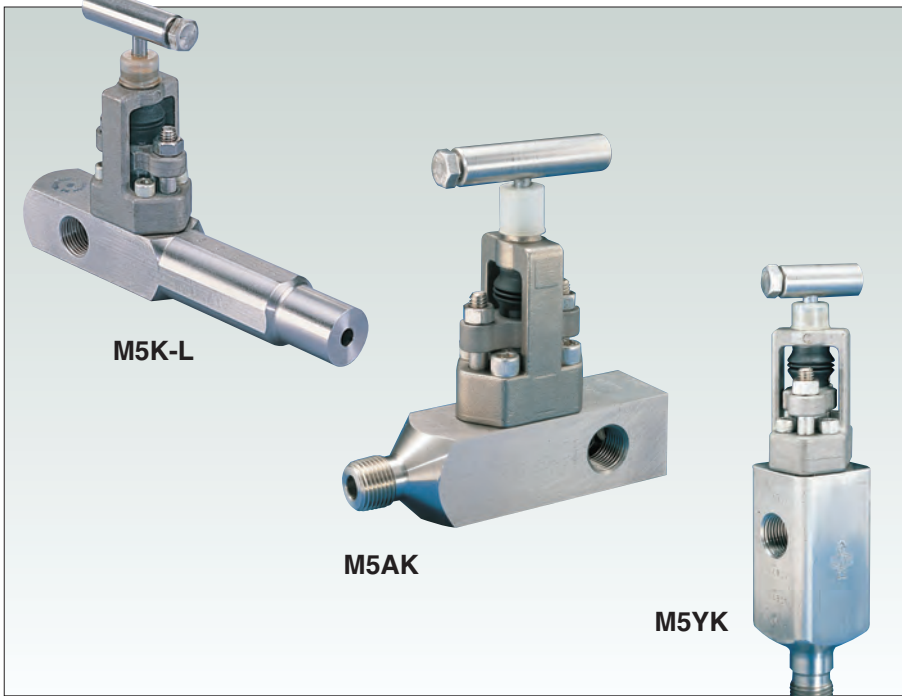

Product Overview

M5K Gauge Valve

The M5K gauge valve is a multi-ported OS&Y root/primary instrument isolation valve, designed for use with gauge mountings and other pressure instruments in refineries and chemical plants. The M5K facilitates installation of multiple measurement devices without additional penetrations of the main piping.

The M5K is available in metal seat design with integral seat, or with various replaceable, roddable soft seats (1/4-inch [6.4 mm] diameter orifice).

M5AK Gauge Valve

The M5AK gauge valve is a multi-ported OS&Y root/primary instrument isolation valve, designed for use with gauge mounting and other instrument ties in refineries and chemical plants. Additional penetrations of the main piping are not required.

The M5AK is available with a variety of replaceable, roddable, metal or soft seats, with 3/8-inch [9.5 mm] diameter orifice. The unique metal seat design offers bubble-tight shutoff with straight-through flow characteristics.

M5YK Gauge Valve

The M5YK gauge valve is a versatile, dual outlet valve for use in gauge mounting or as root/primary isolation valve in differential pressure transmitter installations. In-line construction of body and OS&Y bonnet allows installation and replacement of valves in orifice taps without removal of bonnet assembly.

The valve is designed for safety, service, and economy. The long-necked inlet provides room for insulation and the dual 1/2-inch NPT outlet ports provide an extra outlet for bleeder or sampling valves.

The M5YK is standard with 1/4-inch [6.4 mm] integral seat. Available with seat insert and stem ball of selected metals to match process requirements.

Features and Benefits

- **Four-bolt outside screw and yoke (OS&Y) bonnet** provides easy access to the packing gland. Stem threads are completely isolated from the process. True 4-bolt design.
- **Protective stem bellows and cap** protects against atmospheric contamination and increases the valve life. Bellows and cap help contain stem lubricant (unlike most OS&Y designs) which reduces possible thread galling.
- **Compact design** requires minimum space for operation and installation. Lower valve weight improves strength at the process connection and reduces induced bending moments.
- **Multi-port outlet** means fewer fittings, fewer leak points, and reduced installation cost.
- **Standard SS investment cast yoke** improves valve life by resisting corrosion. Material used is A351-CF8M.
- **Single-piece yoke design** means binding of the stem does not occur as with OS&Y bonnets that use bolts to hold and position the yoke.
- **GRAFOIL® or Teflon® flange gasket ring** offers wide compatibility to process fluids without deteriorating flange gasket (bonnet-to-body).
- **Non-rotating plug design (M5AK)** provides bubble-tight valve closure without metal seat galling and low seating torque.
- **Free-swiveling ball end stem design (M5K, M5YK)** makes for bubble-tight valve closure without seat galling.
- **Integral hard back seat (M5K, M5YK)** protects against stem blowout and provides alternate sealing for longer packing life.
- **Replaceable, roddable soft seat design (M5K, M5AK)** can be specified with the time-proven bubble-tight seat with a fully roddable, bi-directional flow. Standard for the M5K - soft seat orifice diameter is 1/4-inch [6.4 mm] and standard for the M5AK is 3/8-inch [9.5 mm].

OS&Y Root Valves – M5K Specifications

Notes

1. Approximate valve weight:
 - standard 3.5 lb [1.6 kg].
 - long 4.0 lb [1.8 kg]. $\frac{3}{16}$ -inch [4.8 mm] diameter orifice.
 Valve C_v 0.523 maximum
2. For Hastelloy® and SG3 call factory for dimensions and weights.

Metal Seat Dimensions, inches [mm]

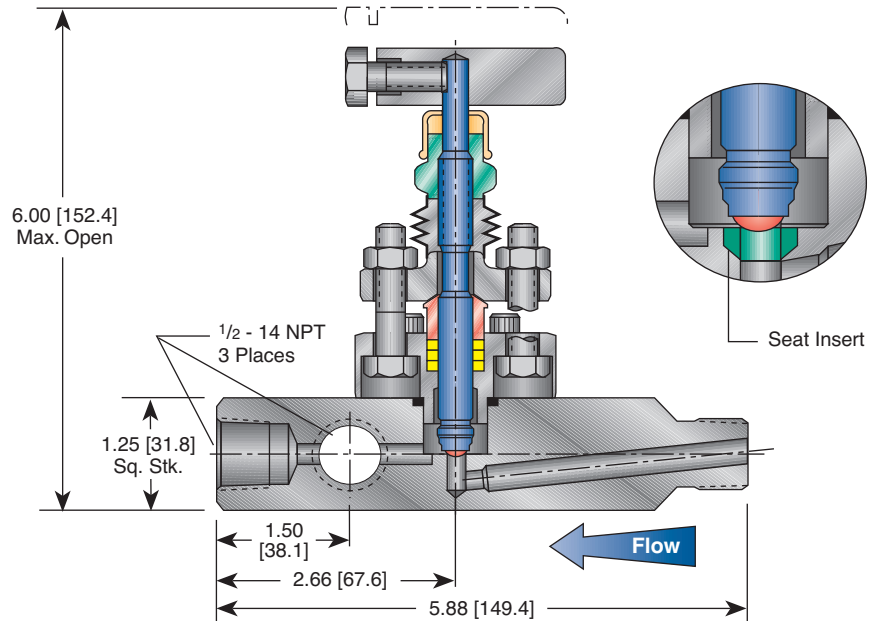

Notes

1. Approximate valve weight:
 - standard 3.5 lb [1.6 kg].
 - long 4.0 lb [1.8 kg].
 1/4-inch [6.4 mm] diameter orifice.
 Valve C_v 1.4 maximum
2. For Hastelloy® and SG3 call factory for dimensions and weights.

Soft Seat Dimensions, inches [mm]

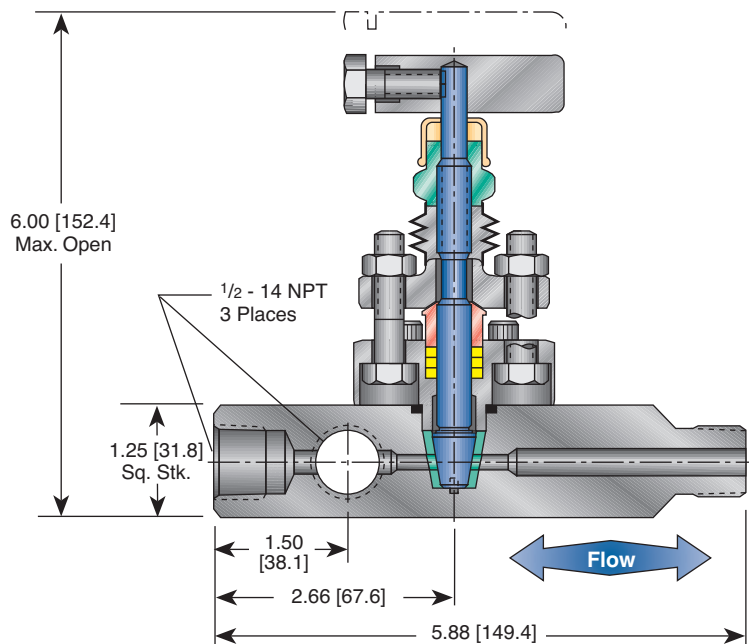

OS&Y Root Valves – M5K Specifications

Standard Materials

Metal Seat

Valve	Body	Stem	Ball	Yoke	Bolt
CS ¹	A105 CS	A581-303 SS	17-4 PH	A351-CF8M	A286
316 SS	A479-316 SS	A276-316 SS	A276-316 SS	A351-CF8M	A286
316L SS	A479-316L SS	A276-316 SS	A276-316 SS	A351-CF8M	A286
SG ²	A479-316 SS	Monel [®] 400	Monel [®] K500	A351-CF8M	A286
SG3 ⁴	Hastelloy [®] C-276	Hastelloy [®] C-276	Elgiloy [®]	A494-CW12MW	A286

Soft Seat

Valve	Body	Stem	Yoke	Bolt	Seat
CS ¹	A105 CS	A582-303 SS	A351-CF8M	A286	Delrin [®]
316 SS	A479-316 SS	A276-316 SS	A351-CF8M	A286	Delrin [®]
316L SS	A479-316L SS	A276-316 SS	A351-CF8M	A286	Delrin [®]
SG ²	A479-316 SS	Monel [®] R405	A351-CF8M	A286	Delrin [®]
SG3 ⁴	Hastelloy [®] C-276	Hastelloy [®] C-276	A494-CW12MW	A286	Delrin [®]

Pressure and Temperature Ratings

Metal Seated

Valve	Packing	Pressure and Temperature Rating	
CS ¹	GRAFOIL [®]	6000 psig @ 200°F 1500 psig @ 850°F	[414 barg @ 93°C] [103 barg @ 454°C]
316 SS, SG ² , SG3 ⁴	GRAFOIL [®]	6000 psig @ 200°F 1500 psig @ 1000°F	[414 barg @ 93°C] [103 barg @ 538°C]
316L SS	GRAFOIL [®]	5000 psig @ 200°F 1500 psig @ 850°F	[345 barg @ 93°C] [103 barg @ 454°C]
CS, 316 SS, SG3 ⁴	Teflon [®]	6000 psig @ 200°F 4000 psig @ 500°F	[414 barg @ 66°C] [276 barg @ 260°C]

Soft Seated

Valve	Packing	Seat Material	Pressure and Temperature Rating	
CS ¹	Teflon [®] or GRAFOIL [®]	Delrin [®] and PCTFE ³	6000 psig @ 200°F	[414 barg @ 93°C]
316 SS	Teflon [®] or GRAFOIL [®]	PEEK	6000 psig @ 200°F 2000 psig @ 400°F	[414 barg @ 93°C] [138 barg @ 204°C]
316L SS	Teflon [®] or GRAFOIL [®]	Teflon [®]	1000 psig @ 150°F 200 psig @ 500°F	[69 barg @ 66°C] [14 barg @ 260°C]
SG3 ⁴	Teflon [®] or GRAFOIL [®]	PEEK	6000 psig @ 200°F 2000 psig @ 400°F	[414 barg @ 93°C] [138 barg @ 204°C]
SG3 ⁴	Teflon [®] or GRAFOIL [®]	Teflon [®]	1000 psig @ 150°F 200 psig @ 500°F	[69 barg @ 66°C] [14 barg @ 260°C]

Notes

1. CS is zinc-cobalt plated to prevent corrosion (except male plain end is black oxide coated).
2. SG (Sour Gas) meets the requirements of NACE MR0175/ISO 15156-3 Corrigendum 2 (for Chloride conditions ≤ 50 mg/l [ppm]) and NACE MR0103-2005.
3. PCTFE (Polychlorotrifluoroethylene) is the exact equivalent of Kel-F[®].
4. SG3 (Sour Gas) meets the requirements of NACE MR0175/ISO 15156-3 Corrigendum 2 (for Chloride conditions > 50 mg/l [ppm]). If accessories are added, consult factory for materials.

OS&Y Root Valves – M5K Specifications

Pressure vs. Temperature – Metal Seat

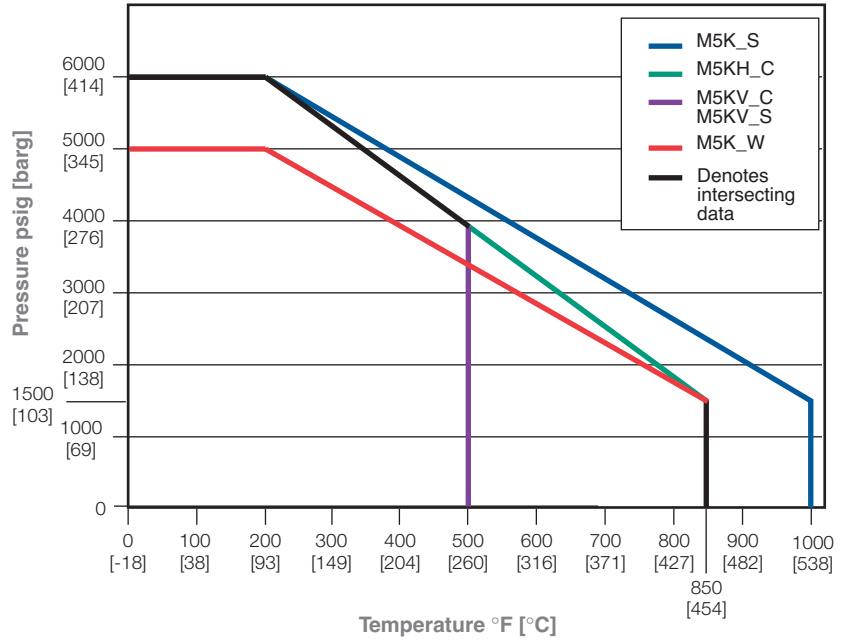

Note

1. PCTFE (Polychlorotrifluoroethylene) is the exact equivalent of Kel-F®.

Pressure vs. Temperature – Soft Seat

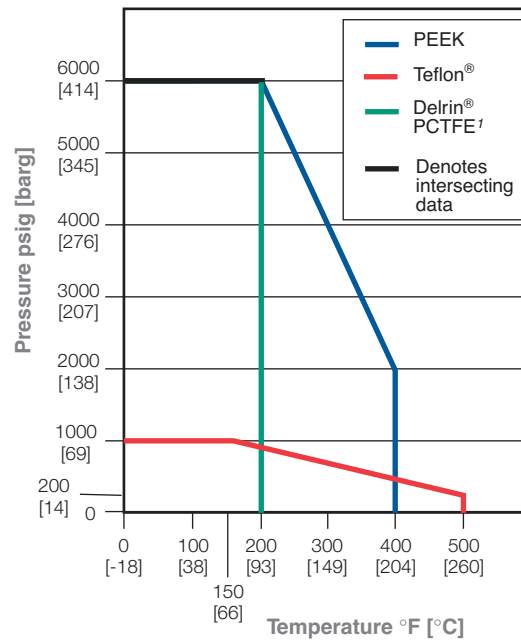

Max. temperature	CS	1500 psig @ 850°F	[103 barg @ 454°C]
	SS	1500 psig @ 1000°F	[103 barg @ 538°C]
Max. pressure	316L SS	5000 psig @ 200°F	[345 barg @ 93°C]

OS&Y Root Valves – M5K Metal Seat Specifications

M5K Ordering Information – Metal Seat

M5K H I S – 44LC – SG

Packing

- H – GRAFOIL®
- V – Teflon®

Seat¹

- I – Integral (standard)

Body Material²

- C – CS, A105³
- S – SS, A479-316
- W – SS, A479-316L
- J – Hastelloy®

Connections (Inlet/Outlet)⁴

- 44 – 1/2-inch MNPT x (3) 1/2-inch FNPT
- 46 – 3/4-inch MNPT x (3) 1/2-inch FNPT
- C – Male plain end (CS is black oxide coated)
- L – Long body extension (4-inch insulation)

Options

- AL – Arctic Lubricant (Low Temperature Service) - not available for CS valves
- CL – Chlorine Cleaning
- HD – Hydrostatic Testing (100%) (MSS SP-61)
- OC – Oxygen Cleaning
- SG – (Sour Gas) meets the requirements of NACE MR0175/ISO 15156-3 Corrigendum 2 (for Chloride conditions ≤ 50 mg/l [ppm]) and NACE MR0103-2005 (SS only)
- SG3 – (Sour Gas) meets the requirements of NACE MR0175/ISO 15156-3 Corrigendum 2 (for Chloride conditions > 50 mg/l [ppm]) - if accessories are added, consult factory for materials
- SP – Special Requirements - please specify

Notes

1. 3/16-inch [4.8 mm] diameter orifice.
2. Call factory for optional materials.
3. CS is zinc-cobalt plated to prevent corrosion (except male plain end is black oxide coated).
4. Call factory for optional connection sizes.

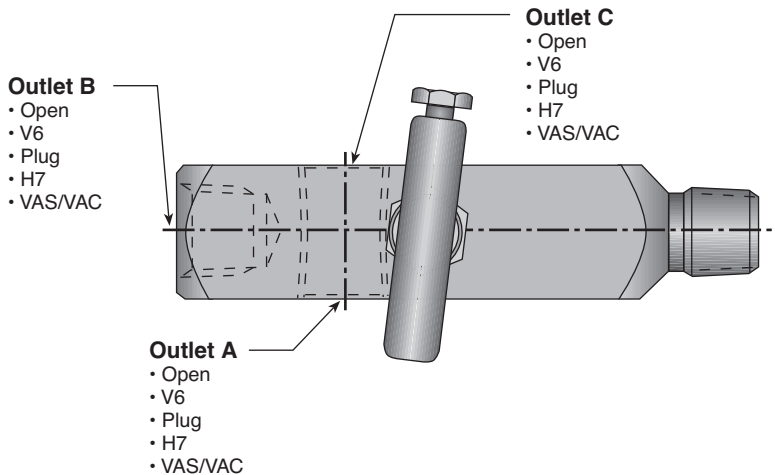

Drawing is illustrated for porting.

OS&Y Root Valves – M5K Soft Seat Specifications

Notes

- 1/4-inch [6.4 mm] diameter orifice.
- PCTFE (Polychlorotrifluoroethylene) is the exact equivalent of Kel-F®.
- Call factory for optional materials.
- CS is zinc-cobalt plated to prevent corrosion (except male plain end is black oxide coated).
- Call factory for optional connection sizes.

M5K Ordering Information – Soft Seat

M5K	V	D	S	- 44LC	- SG
Packing					
H – GRAFOIL®					
V – Teflon®					
Seat¹					
V – Teflon®					
K – PCTFE ²					
E – PEEK					
D – Delrin®					
Body Material³					
C – CS, A105 ⁴					
S – SS, A479-316					
W – SS, A479-316L					
J – Hastelloy®					
Connections (Inlet/Outlet)⁵					
44 – 1/2-inch MNPT x (3) 1/2-inch FNPT					
46 – 3/4-inch MNPT x (3) 1/2-inch FNPT					
C – Male plain end (CS is black oxide coated)					
L – Long body extension (4-inch insulation)					
Options					
AL – Arctic Lubricant (Low Temperature Service) - not available for CS valves					
CL – Chlorine Cleaning					
HD – Hydrostatic Testing (100%) (MSS SP-61)					
OC – Oxygen Cleaning					
SG – (Sour Gas) meets the requirements of NACE MR0175/ISO 15156-3 Corrigendum 2 (for Chloride conditions ≤ 50 mg/l [ppm]) and NACE MR0103-2005 (SS only)					
SG3 – (Sour Gas) meets the requirements of NACE MR0175/ISO 15156-3 Corrigendum 2 (for Chloride conditions > 50 mg/l [ppm]) - if accessories are added, consult factory for materials					
SP – Special Requirements - please specify					

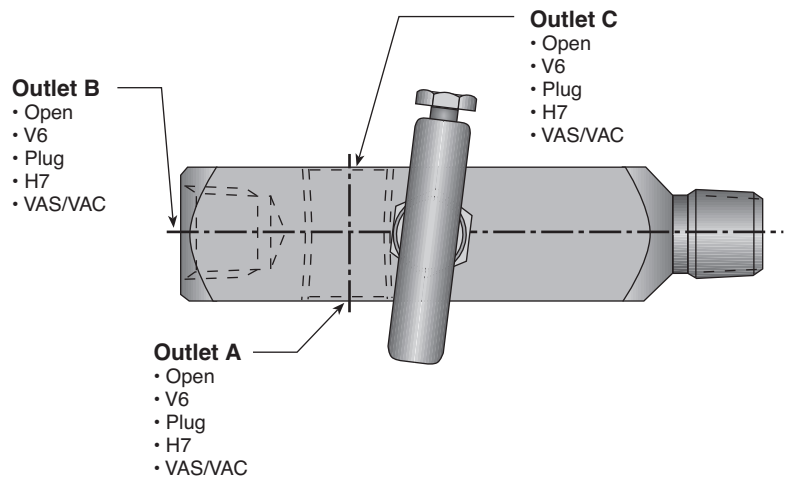

Drawing is illustrated for porting.

OS&Y Root Valves – M5AK Specifications

M5AK Metal and Soft Seat Dimensions, inches [mm]

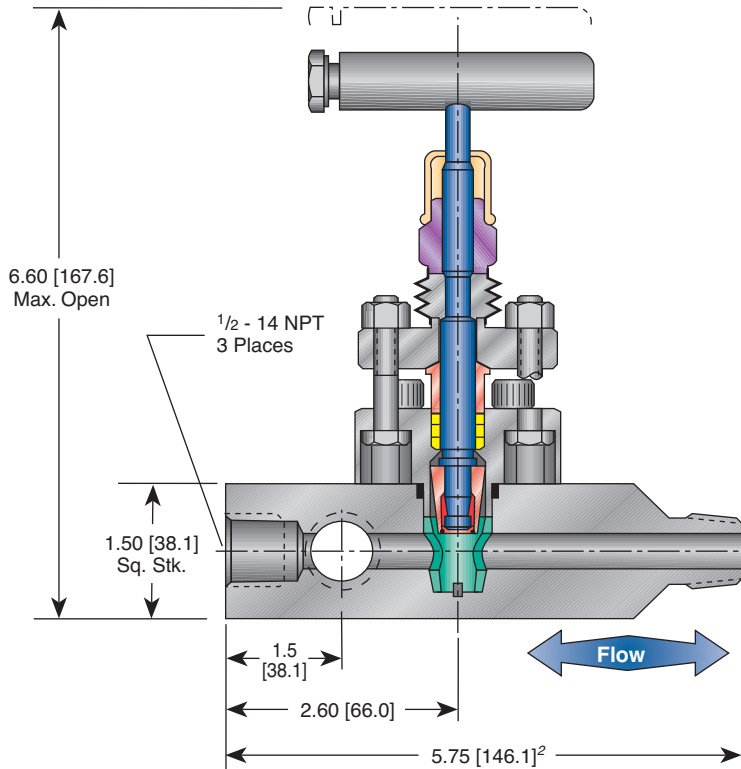

Notes

1. Approximate valve weight:
- standard 4.0 lb [1.8 kg].
- long 4.5 lb [2.0 kg].
3/8-inch [9.5] diameter orifice.
Valve C_v 3.0 maximum.
2. Long body length 7.75-inch [196.8 mm]
4-inch insulation.
3. For Hastelloy® and SG3, call factory for dimensions and weights.

Standard Materials

Metal Seat

Valve	Body	Stem	Yoke	Bolt
CS ¹	A105 CS	A581-303 SS	A351-CF8M	A574
316 SS	A479-316 SS	A276-316 SS	A351-CF8M	A574
316L SS	A479-316L SS	A276-316 SS	A351-CF8M	A574
SG ²	A479-316 SS	Monel® R405	A351-CF8M	A574
SG3 ³	Hastelloy® C-276	Hastelloy® C-276	A494-CW12MW	A574

Soft Seat

Valve	Body	Stem	Yoke	Bolt	Seat ⁴
CS ¹	A105 CS	A581-303 SS	A351-CF8M	A574	Delrin®
316 SS	A479-316 SS	A276-316 SS	A351-CF8M	A574	Delrin®
316L SS	A479-316L SS	A276-316 SS	A351-CF8M	A574	Delrin®
SG ²	A479-316 SS	Monel® R405	A351-CF8M	A574	Delrin®
SG3 ³	Hastelloy® C-276	Hastelloy® C-276	A494-CW12MW	A574	Delrin®

Notes

1. CS is zinc-cobalt plated to prevent corrosion (except male plain end is black oxide coated).
2. SG (Sour Gas) meets the requirements of NACE MR0175/ISO 15156-3 Corrigendum 2 (for Chloride conditions ≤ 50 mg/l [ppm]) and NACE MR0103-2005.
3. SG3 (Sour Gas) meets the requirements of NACE MR0175/ISO 15156-3 Corrigendum 2 (for Chloride conditions > 50 mg/l [ppm]). If accessories are added, consult factory for materials.
4. Teflon®, PCTFE and PEEK are available.

OS&Y Root Valves – M5AK Specifications

Notes

1. CS is zinc-cobalt plated to prevent corrosion (except male plain end is black oxide coated).
2. SG (Sour Gas) meets the requirements of NACE MR0175/ISO 15156-3 Corrigendum 2 (for Chloride conditions ≤ 50 mg/l [ppm]) and NACE MR0103-2005.
3. PCTFE (Polychlorotrifluoroethylene) is the exact equivalent of Kel-F®.
4. SG3 (Sour Gas) meets the requirements of NACE MR0175/ISO 15156-3 Corrigendum 2 (for Chloride conditions > 50 mg/l [ppm]). If accessories are added, consult factory for materials.

Pressure and Temperature Ratings

Metal Seat

Valve	Teflon® Packed	GRAFOIL® Packed
CS ¹	1500 psig @ 500°F [103 barg @ 260°C]	1500 psig @ 850°F [103 barg @ 454°C]
316 SS	1500 psig @ 500°F [103 barg @ 260°C]	1500 psig @ 850°F [103 barg @ 454°C]
316L SS	1500 psig @ 500°F [103 barg @ 260°C]	1500 psig @ 850°F [103 barg @ 454°C]
SG ² , SG ³ ⁴	1500 psig @ 500°F [103 barg @ 260°C]	1500 psig @ 850°F [103 barg @ 454°C]

Soft Seat

Valve	Delrin®	PCTFE ³	PEEK	Teflon®
CS ¹			6000 psig @ 200°F [414 barg @ 93°C]	1000 psig @ 150°F [69 barg @ 66°C]
316 SS, SG ² , SG ³ ⁴	6000 psig @ 200°F [414 barg @ 93°C]	5000 psig @ 200°F [345 barg @ 93°C]	2000 psig @ 400°F [138 barg @ 204°C]	200 psig @ 500°F [14 barg @ 260°C]
316L SS	5000 psig @ 200°F [345 barg @ 93°C]	5000 psig @ 200°F [345 barg @ 93°C]	5000 psig @ 200°F [345 barg @ 93°C] 2000 psig @ 400°F [138 barg @ 204°C]	1000 psig @ 150°F [69 barg @ 66°C] 200 psig @ 500°F [14 barg @ 260°C]

Pressure vs. Temperature – Metal Seat

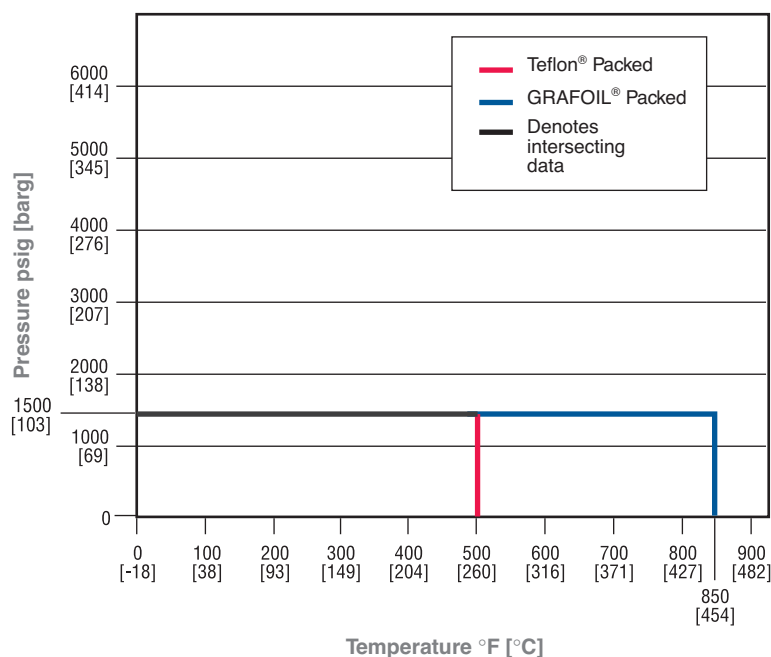

Pressure vs. Temperature – Soft Seat

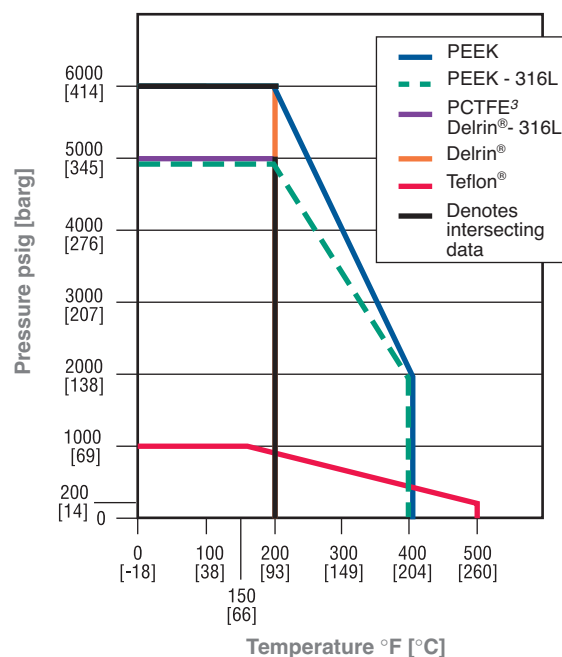

OS&Y Root Valves – M5AK Metal Seat Specifications

M5AK Ordering Information – Metal Seat

M5AK **H** **S** **S** **- 44C** **- SG**

Packing

- H – GRAFOIL®
- V – Teflon®

Seat

- S – 316 SS
- M – Monel®

Body Material¹

- C – CS, A105
- S – SS, A479-316
- W – SS, A479-316L
- J – Hastelloy®

Connections (Inlet/Outlet)²

- 44 – 1/2-inch MNPT x (3) 1/2-inch FNPT
- 46 – 3/4-inch MNPT x (3) 1/2-inch FNPT
- C – Male plain end (inlet) (CS is black oxide coated)

Options

- AL – Arctic Lubricant (Low Temperature Service) - not available for CS valves
- CL – Chlorine Cleaning
- HD – Hydrostatic Testing (100%) (MSS SP-61)
- OC – Oxygen Cleaning
- SG – (Sour Gas) meets the requirements of NACE MR0175/ISO 15156-3 Corrigendum 2 (for Chloride conditions ≤ 50 mg/l [ppm]) and NACE MR0103-2005 (SS only)
- SG3 – (Sour Gas) meets the requirements of NACE MR0175/ISO 15156-3 Corrigendum 2 (for Chloride conditions > 50 mg/l [ppm]) - if accessories are added, consult factory for materials
- SP – Special Requirements - please specify

Notes

1. Call factory for optional materials.
2. Call factory for optional connection sizes.

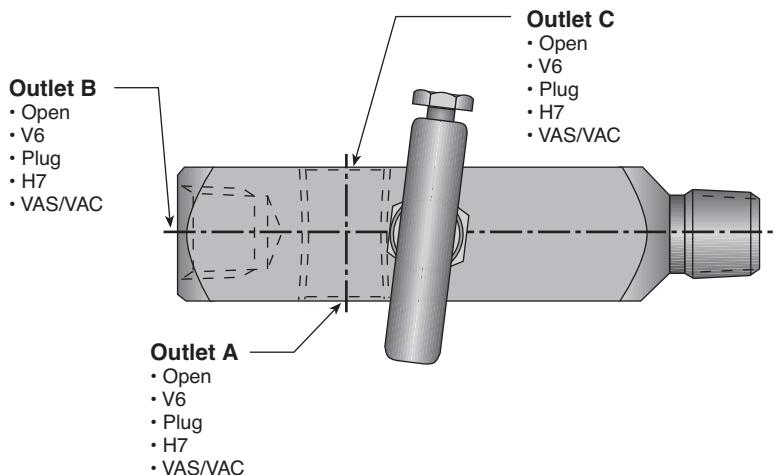

Drawing is illustrated for porting.

OS&Y Root Valves – M5AK Soft Seat Specifications

Notes

1. PCTFE (Polychlorotrifluoroethylene) is the exact equivalent of Kel-F®.
2. Call factory for optional materials.
3. Call factory for optional connection sizes.

M5AK Ordering Information – Soft Seat

M5AK	V	V	S	- 44C	- SG
Packing					
H – GRAFOIL®					
V – Teflon®					
Seat					
V – Teflon®					
D – Delrin®					
E – PEEK					
K – PCTFE ¹					
Body Material²					
C – CS, A105					
S – SS, A479-316					
W – SS, A479-316L					
J – Hastelloy®					
Connections (Inlet/Outlet)³					
44 – 1/2-inch MNPT x (3) 1/2-inch FNPT					
46 – 3/4-inch MNPT x (3) 1/2-inch FNPT					
C – Male plain end (inlet) (CS is black oxide coated)					
Options					

- AL – Arctic Lubricant (Low Temperature Service) - not available for CS valves
- CL – Chlorine Cleaning
- HD – Hydrostatic Testing (100%) (MSS SP-61)
- OC – Oxygen Cleaning
- SG – (Sour Gas) meets the requirements of NACE MR0175/ISO 15156-3 Corrigendum 2 (for Chloride conditions ≤ 50 mg/l [ppm]) and NACE MR0103-2005 (SS only)
- SG3 – (Sour Gas) meets the requirements of NACE MR0175/ISO 15156-3 Corrigendum 2 (for Chloride conditions > 50 mg/l [ppm]) - if accessories are added, consult factory for materials
- SP – Special Requirements - please specify

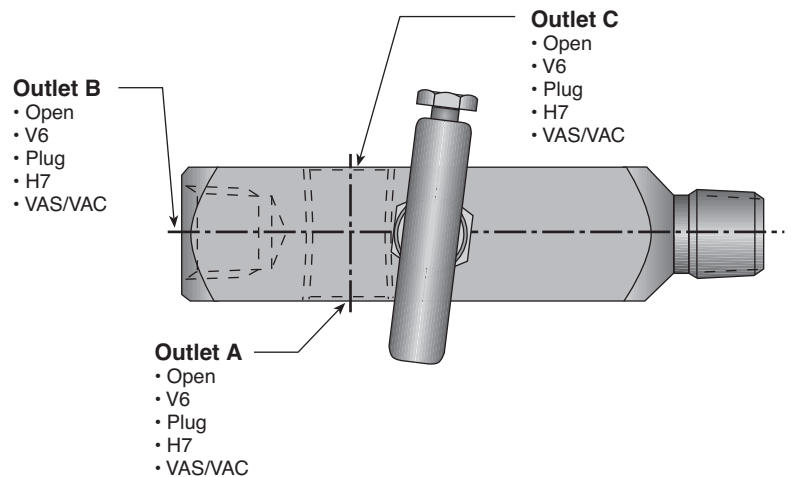

Drawing is illustrated for porting.

OS&Y Root Valves – M5YK Specifications

Dimensions, inches [mm]

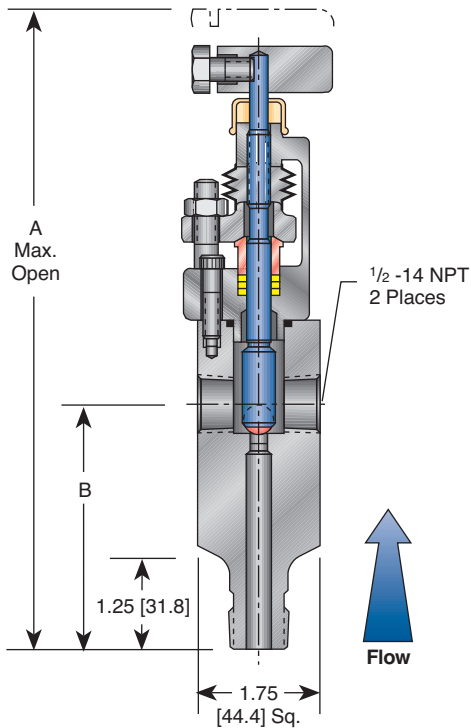

Dimensions, inches [mm]

Body Type	A	B	Weight lb [kg]
Standard	9.20 [233.7]	3.50 [88.9]	4.5 [2.0]
Long Body	11.70 [297.2]	6.00 [152.4]	7.0 [3.2]

Standard Materials

Valve ¹	Body ²	Stem	Ball	Yoke	Bolt
CS ³	A696-Gr C	A276-316 SS	17-4PH	A351-CF8M	A286
316 SS	A479-316 SS	A276-316 SS	A276-316 SS	A351-CF8M	A286
316L SS	A479-316L SS	A276-316 SS	A276-316 SS	A351-CF8M	A286
SG ⁴	A479-316 SS	Monel® R405	Monel® K500	A351-CF8M	A286
SG3 ^{5,6}	Hastelloy® C-276	Hastelloy® C-276	Elgiloy®	A494-CW12MW	A286

Notes

1. Orifice size 1/4-inch [6.4 mm].
Valve C_v 1.4 maximum.
3. Call factory for optional materials.
3. CS is zinc-cobalt plated to prevent corrosion.
4. SG (Sour Gas) meets the requirements of NACE MR0175/ISO 15156-3 Corrigendum 2 (for Chloride conditions ≤ 50 mg/l [ppm]) and NACE MR0103-2005.
5. For Hastelloy® and SG3 call factory for dimensions and weights.
6. SG3 (Sour Gas) meets the requirements of NACE MR0175/ISO 15156-3 Corrigendum 2 (for Chloride conditions > 50 mg/l [ppm]).
If accessories are added, consult factory for materials.

OS&Y Root Valves – M5YK Specifications

Pressure and Temperature Ratings

Valve	GRAFOIL® Packing		Teflon® Packing	
CS	6000 psig @ 200°F	[414 barg @ 93°C]	6000 psig @ 200°F	[414 barg @ 93°C]
	1500 psig @ 850°F	[103 barg @ 454°C]	4000 psig @ 500°F	[276 barg @ 260°C]
316 SS	6000 psig @ 200°F	[414 barg @ 93°C]	6000 psig @ 200°F	[414 barg @ 93°C]
	1500 psig @ 1000°F	[103 barg @ 538°C]	4000 psig @ 500°F	[276 barg @ 260°C]
316L SS	5000 psig @ 200°F	[345 barg @ 93°C]	5000 psig @ 200°F	[345 barg @ 93°C]
	1500 psig @ 850°F	[103 barg @ 454°C]	4000 psig @ 500°F	[276 barg @ 260°C]
SG ¹ , SG3 ²	6000 psig @ 200°F	[414 barg @ 93°C]	6000 psig @ 200°F	[414 barg @ 93°C]
	1500 psig @ 1000°F	[103 barg @ 538°C]	4000 psig @ 500°F	[276 barg @ 260°C]

Notes

1. SG (Sour Gas) meets the requirements of NACE MR0175/ISO 15156-3 Corrigendum 2 (for Chloride conditions ≤ 50 mg/l [ppm]) and NACE MR0103-2005.
2. SG3 (Sour Gas) meets the requirements of NACE MR0175/ISO 15156-3 Corrigendum 2 (for Chloride conditions > 50 mg/l [ppm]). If accessories are added, consult factory for materials.

Pressure vs. Temperature

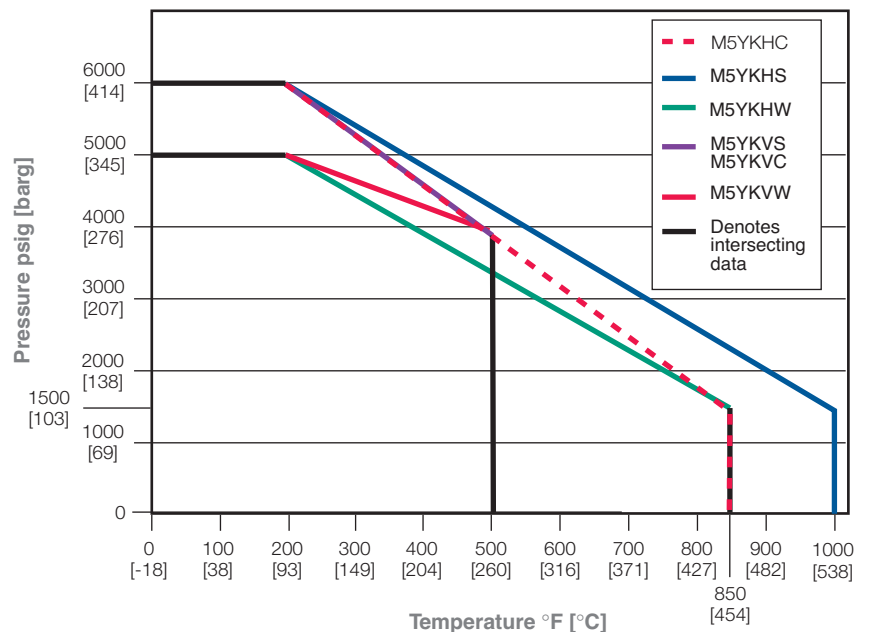

OS&Y Root Valves – M5YK Specifications

Ordering Information

M5YK H I S – 44LC – SG

Packing

- H – GRAFOIL®
- V – Teflon®

Seat (Orifice diameter 1/4-inch [6.4 mm])

- I – Integral (standard)
- S – 316 SS Insert
- M – Monel® Insert
- T – Stellite Insert/Stellite Ball

Body Material¹

- C² – CS, A696 Gr C (A105)
- S – SS, A479-316
- W – SS, A479-316L
- J – Hastelloy®

Connections (Inlet/Outlet)

- 44 – 1/2-inch MNPT x (2) 1/2-inch FNPT
- 46 – 3/4-inch MNPT x (2) 1/2-inch FNPT
- 48 – 1-inch MNPT x (2) 1/2-inch FNPT

- C – Male plain end (inlet) (CS is black oxide coated)
- L – Long body extension (4-inch [102 mm] insulation) (not available as -44L)

Options

- AL – Arctic Lubricant (Low Temperature Service) - not available for CS valves
- P – Power, ASME B31.1 and B31.3 (GRAFOIL® packing with integral seat only) (consult factory for ratings) meets MSS SP-105
- SG – (Sour Gas) meets the requirements of NACE MR0175/ISO 15156-3 Corrigendum 2 (for Chloride conditions ≤ 50 mg/l [ppm]) and NACE MR0103-2005 (SS only)
- SG3 – (Sour Gas) meets the requirements of NACE MR0175/ISO 15156-3 Corrigendum 2 (for Chloride conditions > 50 mg/l [ppm]) - if accessories are added, consult factory for materials
- SP – Special Requirements - please specify

Notes

1. Call factory for optional materials.
2. A696 Gr C is the bar stock equivalent to A105 carbon steel.

Gauge Valve Accessories – Bleed Tee (BT)

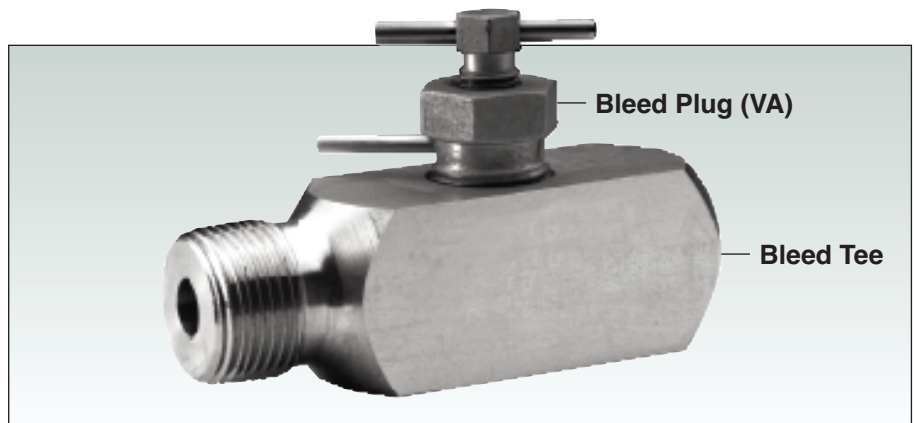

Product Overview

The Anderson Greenwood Bleed Tee is a single male inlet, triple female outlet piping tee. It is generally used with the process root valve to simplify downstream piping and reduce the number of potential leak points.

The Bleed Tee can be used with any 1/2-inch or 3/4-inch valve in an instrument piping system and allows either vertical or horizontal pressure gauge mounting. As an option, a bleed plug (as shown above) can be assembled into the tee to provide a means of relieving pressure for maintenance purposes.

Features and Benefits

- **Multiple outlets** reduce piping/tubing leak points and permit a pressure gauge or other device to be correctly positioned regardless of tee orientation.
- **Compact installation** shortens moment arm, reducing weight and vibration factors. With stress limited, the chances of breakage and leaks are greatly lowered.
- **Straight-through flow path** provides high flow capacity, bi-directional flow, and rodding capabilities.
- **Bleed plug:** (optional) in one outlet, shown above, serves to reduce pressure for instrument removal, facilitating maintenance.
- **Direction tube** located in bleed port.

Gauge Valve Accessories – Bleed Tee Specifications

Bleed Tee Dimensions, inches [mm]

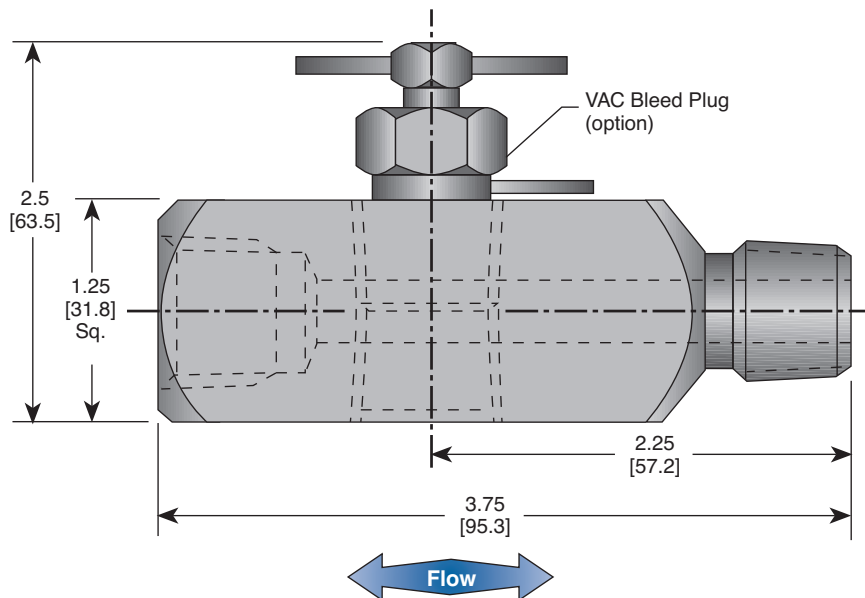

Standard Materials

Valve ¹	Body	Bleed Plug	Bleed Stem
CS ²	A105 CS	A108 CS	A581-303 SS
316 SS	A479 316 SS	A479 316 SS	A276-316 SS
SG ⁴	A479 316 SS	A479 316 SS	Monel® R405
SG3 ⁵	Hastelloy® C-276	Hastelloy® C-276	Hastelloy® C-276

Notes

- Valve weight: 1.0 lb [.45 kg] each.
Orifice diameter of bleed tee
0.375-inch [9.5 mm].
Orifice diameter of bleed valve
0.125-inch [3.2 mm].
- CS is zinc-cobalt plated to prevent corrosion.
- For Hastelloy® and SG3 call factory for dimensions and weights.
- SG (Sour Gas) meets the requirements of NACE MR0175/ISO 15156-3 Corrigendum 2 (for Chloride conditions ≤ 50 mg/l [ppm]) and NACE MR0103-2005.
- SG3 (Sour Gas) meets the requirements of NACE MR0175/ISO 15156-3 Corrigendum 2 (for Chloride conditions > 50 mg/l [ppm]). If accessories are added, consult factory for materials.

Pressure and Temperature Ratings

Bleed Tee Body

CS ²	6000 psig @ 200°F [414 barg @ 93°C]	1500 psig @ 850°F [103 barg @ 454°C]
316 SS, SG ⁴ , SG3 ⁵	6000 psig @ 200°F [414 barg @ 93°C]	1500 psig @ 1000°F [103 barg @ 538°C]

Bleed Tee with Bleed Plug

CS ²	6000 psig @ 200°F [414 barg @ 93°C]	4000 psig @ 500°F [276 barg @ 200°C]
316 SS, SG ⁴ , SG3 ⁵	6000 psig @ 200°F [414 barg @ 93°C]	1500 psig @ 1000°F [103 barg @ 538°C]

Gauge Valve Accessories – Bleed Tee Specifications

Pressure vs. Temperature

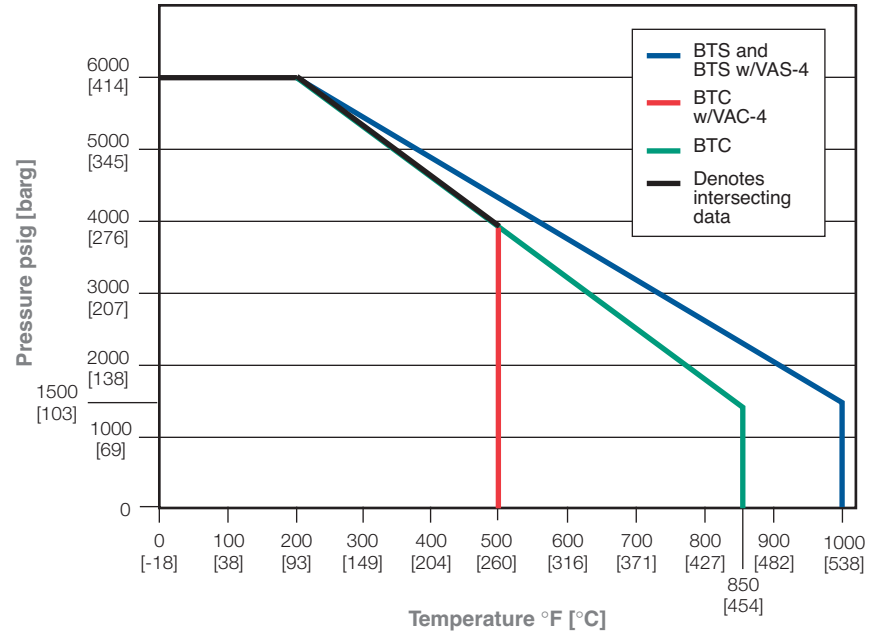

Ordering Information

BT C - 44 - VAC-4

Body Material

- C - CS, A105
- S - SS, A479-316
- J - Hastelloy®

Connections (Inlet/Outlet)

- 44 - 1/2-inch MNPT x (3) 1/2-inch FNPT
- 46 - 3/4-inch MNPT x (3) 1/2-inch FNPT

Options

- VAC-4 - 1/2-inch CS Bleed Plug
- VAS-4 - 1/2-inch SS Bleed Plug
- VAJ-4 - 1/2-inch Hastelloy® Bleed Plug
- SG - (Sour Gas) meets the requirements of NACE MR0175/ISO 15156-3 Corrigendum 2 (for Chloride conditions ≤ 50 mg/l [ppm]) and NACE MR0103-2005 (SS only)
- SG3 - (Sour Gas) meets the requirements of NACE MR0175/ISO 15156-3 Corrigendum 2 (for Chloride conditions > 50 mg/l [ppm]) - if accessories are added, consult factory for materials

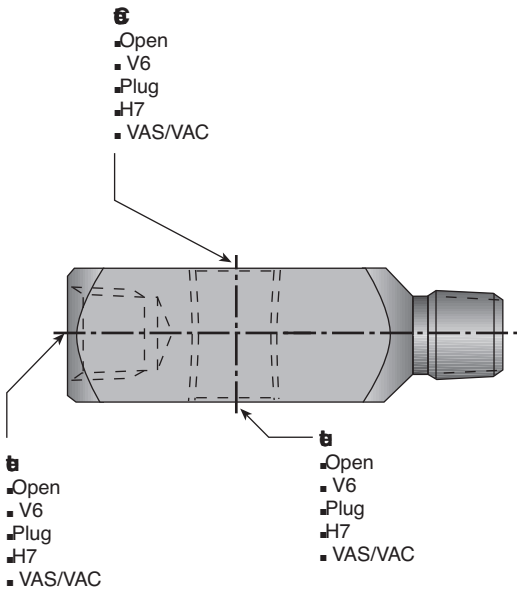

Gauge Valve Accessories

V6 Bleeder Valve

The V6 Bleeder Valve utilizes H5 miniature valve bonnet technology. The H5 bonnet and seat are integrated with a hex plug body to produce a bleeder valve that vents to atmosphere and has bubble-tight shutoff.

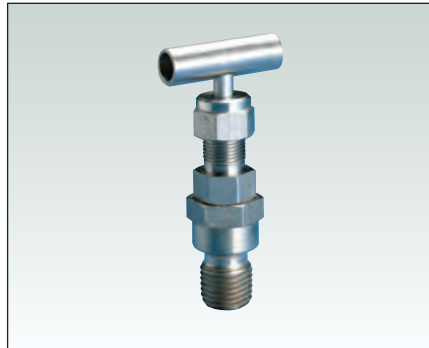

Notes

1. CS is zinc-cobalt plated to prevent corrosion.
2. Standard 1/2-inch NPT plug made from hex barstock. Available in CS, 316 SS or Monel®.
3. SG (Sour Gas) meets the requirements of NACE MR0175/ISO 15156-3 Corrigendum 2 (for Chloride conditions ≤ 50 mg/l [ppm]) and NACE MR0103-2005.
4. SG3 (Sour Gas) meets the requirements of NACE MR0175/ISO 15156-3 Corrigendum 2 (for Chloride conditions > 50 mg/l [ppm]). If accessories are added, consult factory for materials.

Pressure and Temperature Ratings

Brass

Hard seat/Teflon® seal	3000 psig @ 400°F	[207 barg @ 204°C]
Hard seat/O-ring seal	3000 psig @ 200°F	[207 barg @ 93°C]
Soft seat/Either seal		

CS¹, SS, SG³ and SG⁴

Hard seat/Teflon® seal	6000 psig @ 200°F	[414 barg @ 93°C]
	4000 psig @ 500°F	[276 barg @ 260°C]
Hard seat/O-ring seal	6000 psig @ 200°F	[414 barg @ 93°C]
Soft seat/Either seal	3000 psig @ 200°F	[207 barg @ 93°C]

Standard Product Selection

	Connections Inlet	O-ring		Teflon® Packed	
		Hard	Soft	Hard	Soft
Brass	1/2-inch NPT	V6RIB-4	V6RDB-4	V6VIB-4	V6VDB-4
CS ¹	1/2-inch NPT	V6RIC-4	V6RDC-4	V6VIC-4	V6VDC-4
SS, SG ³ , SG ⁴	1/2-inch NPT	V6RIS-4	V6RDS-4	V6VIS-4	V6VKS-4

VA Bleed Plug²

The VA bleed plug provides an economic means to bleed process pressure trapped between the M5 and instrument.

Model Number

CS ¹	316 SS	Monel®	Sour Gas ^{3, 4}
VAC-4	VAS-4	VAM-4	VAS-4-SG VAS-4-SG3



Gauge Valve Accessories

Seat Resurfacing Tool

The flow of abrasive fluids may, over time, score the seating surface of the valve body. The seat resurfacing tool will re-machine this surface and allow the valve to once again deliver bubble-tight shutoff.

Model Number	Description
SRT-1	Seat resurfacing tool for 3/16-inch [4.8 mm] diameter orifice metal seat valves

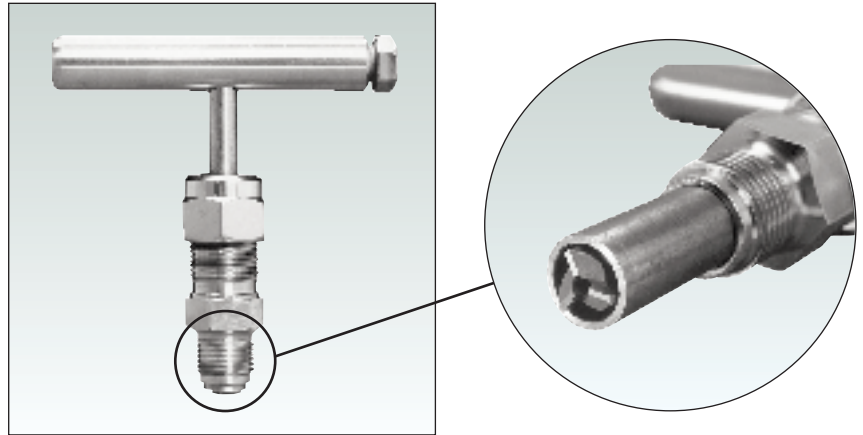

Bonnet Lock (patent protected)

The Bonnet Lock (BL) prevents accidental loosening of the bonnet-to-body seal, and is a low-cost alternative to a union bonnet. A high-strength short bonnet pin aligns a hex collar over the bonnet. A standard SS hollow-point set-screw or lock nut locks the collar against the bonnet. Tests indicate that the minimum torque required to break the collar loose is greater than the torque required to twist off the valve stem. Available only on GRAFOIL® bonnet assemblies.

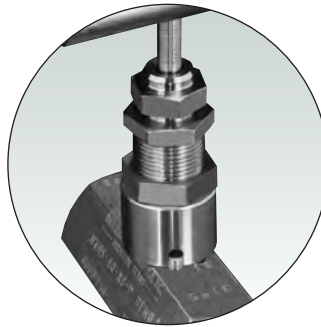

GRAFOIL® Packed Bonnet
Lock Nut

Gauge Adapters

Designed for use with any gauge valve to increase site versatility, the GA swivel gauge adapter allows positioning of pressure gauges in any direction through 360 degrees via a compression fitting.

Gauge Syphons

Designed to replace the old pigtail type of syphon, the CT7 provides a thermal barrier between hot vapors and the pressure instrument. The CT7 reduces the amount of potential gauge whip on vibrating lines by bringing the gauge closer to the process connection. Also used for sealing pressure gauges from aqueous solutions using kerosene or other immiscible fluid with lower gravity than I.O.



Gauge Adapters



Gauge Syphons

Gauge Valve Accessories

Dimensions, inches [mm]

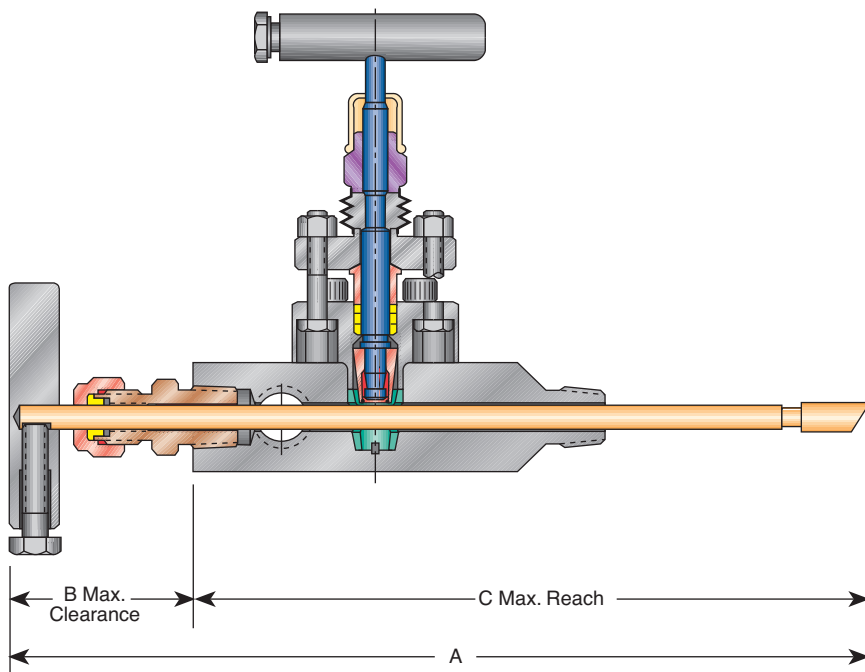

Rod-Out Device with M5AK Gauge Valve

Rod-Out Device Specifications¹, inches [mm]

Model Number	Max. Dia. ² Bore	Rod ³	Gland ⁴	Inlet Connection	Dimensions ³		
					A	B	C
RTV3C-N4 ⁵	3/8" [9.5]	A108 CS ⁵	A108 CS	1/2" NPT	18.1 [459]	15.9 [404]	17.8 [452]
RTV3S-N4	3/8" [9.5]	316 SS	316 SS	1/2" NPT	18.1 [459]	15.9 [404]	17.8 [452]
RTV3M-N4	3/8" [9.5]	Monel® R405	Monel® R405	1/2" NPT	18.1 [459]	15.9 [404]	17.8 [452]
RTV1C-N4 ⁵	3/16" [4.8]	4130 SS	A108 CS	1/2" NPT	12.1 [397]	10.1 [256]	11.8 [300]
RTV1S-N4	3/16" [4.8]	316 SS	316 SS	1/2" NPT	12.1 [397]	10.1 [256]	11.8 [300]
RTV1M-N4	3/16" [4.8]	Monel® R400	Monel® R405	1/2" NPT	12.1 [397]	10.1 [256]	11.8 [300]

Rod-Out Device

The Rod-Out is a device to rod-through passages that have become restricted. It is designed to be used while the valve is not under pressure. It can be left in place while the valve is under pressure. The centerless ground rod has a hardened cutting end larger than the shaft to prevent 'blowout' through the adjustable packing gland. The Rod-Out is available with a 3/16-inch [4.8 mm] or 3/8-inch [9.5 mm] diameter rod.

Notes

- Maximum recommended usage:
500 psig @ 100°F [35 barg @ 37°C].
100 psig @ 500°F [7 barg @ 260°C].
- Rod tip for 3/8-inch [9.5 mm] bore is 0.312-inch [7.9 mm] diameter.
Rod tip for 3/16-inch [4.8 mm] bore is 0.141-inch [3.0 mm] diameter.
- For special rod lengths, materials or connections, consult factory.
- Teflon® packing.
- 3/8-inch [9.5 mm] diameter device is 1.0 lb [0.45 kg] each.
3/16-inch [4.8 mm] diameter device is 0.5 lb [0.23 kg] each.
- CS is zinc-cobalt plated to resist corrosion.

Gauge Valve Accessories

Dimensions, inches [mm]

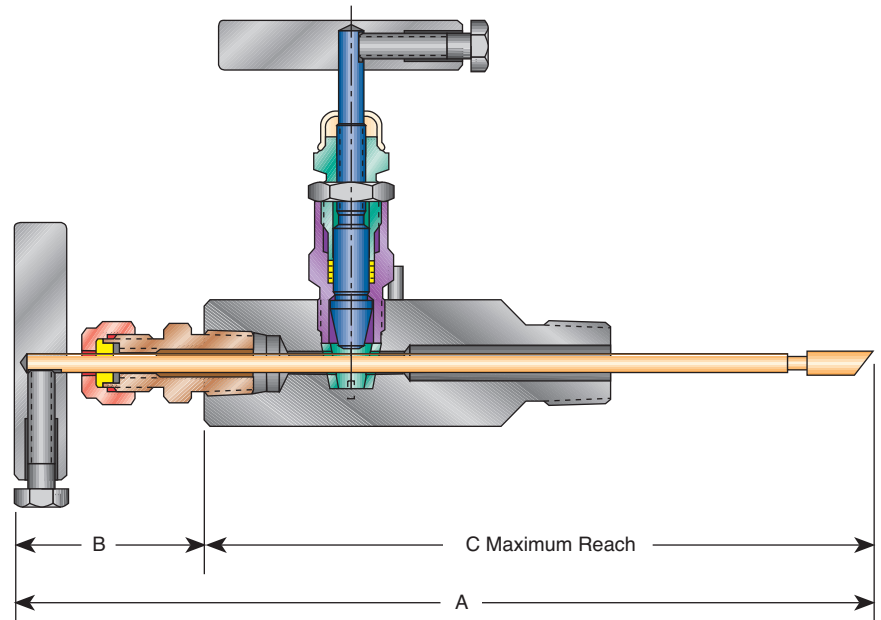

Rod-Out Device with M5 Gauge Valve

Rod-Out Device Ordering Information

RTV¹ 3 S - N4

Bore Diameter

- 1 - 3/16-inch [4.8 mm]
- 3 - 3/8-inch [9.5 mm]

Material

- C - CS (A108) (3/8-inch) [9.5 mm]
(4130) (3/16-inch) [4.8 mm]
- S - 316 SS
- M - Monel® R405 (3/8-inch) [9.5 mm]
Monel® 400 (3/16-inch) [4.8 mm]

Connections

- N4 - 1/2-inch MNPT
- A3 - 3/8-inch AGCO Tube
- A4 - 1/2-inch AGCO Tube

Note

1. V - Teflon® packing gland.